

REPORT OF UNDERWAY pCO<sub>2</sub> MEASUREMENTS IN SURFACE WATERS  
AND THE ATMOSPHERE DURING March 2002

**R/V Laurence M. Gould 02/2**

S. C. Sutherland, Taro Takahashi, Colm Sweeney

Lamont-Doherty Earth Observatory of Columbia University  
Palisades, NY 10964

**31 July, 2017**

**1. General**

**1-a) The Cruise:**

1) This cruise was another in the Palmer Shuttle series between Punta Arenas, Chile and Palmer Station, Antarctica. The ship left Punta Arenas on 22 March 2002 and arrived at Palmer Station on 26 March. She returned to Punta Arenas, departing Palmer Station on 29 March and arriving Punta Arenas on 2 April 2002.

2) Regarding SST (Thermosalinograph (TSG) Temperature). The TSG was unreliable, and we used equilibrator temperature to estimate SST. We use 1 scan offset to adjust the pCO<sub>s</sub> timing.

**1-b) General Comments on the Data:**

This cruise was very challenging to edit. There were 6 periods where the high standard flow stopped, and one where it and the 251.79 ppm standard flow stopped. For the periods where the high standard was not flowing, but the other 4 were, we used the middle three standards fit to a quadratic response curve. For the other periods, where all 5 standard were available, we use all 5 standards fit to a 4<sup>th</sup> order response curve. The rationale here is that we best know the value of our standards, and errors or non-linearities in the response are due to system response issues, (i.e. the linearizing circuit in the Licor Analyzer, problems with inadequate drying of the gas, cell temperature changes, etc.). By using a 4<sup>th</sup> order curve, we utilized all the information from our standard values. Where the two systems meet, the change in VCO<sub>2</sub> is less than 0.5 ppm.

**1-c) The pCO<sub>2</sub> data:**

The primary source of data are files created by the ships data acquisition system, (RVDAS). A program runs to combined pCO<sub>2</sub> data, thermosalinograph (TSG) data, and several other parameters, such as latitude, longitude, windspeed, ship heading and speed, etc. We used raw pCO<sub>2</sub>, TSG temperature and salinity, and position from the ship's GPS data in the merged RVDAS file. These files have the name: LMG0202pco2m.dxxx, where xxx is the 3 digit Julian Date.

Thirty seawater and one air observation are made between standard sets. Each observation involves flowing the equilibration gas for 120 seconds. We also flow the air for 120 seconds before stopping for an observation. Details on these and other aspects of the analysis system are explained later.

**Standards:**

Cylinder	Concentration (ppm)
Nitrogen (UHP)	0.0
CC46457	150.19
CC51612	353.77
CC22986	251.79
CC46471	788.0

A 4<sup>th</sup> order calibration curve is used with 5 standards, and a 2<sup>nd</sup> order one where there is no high standard, as described in Section 2.

Standards flow for about 70 seconds before an observation is made.

**1-d) AIR data:**

There are **61 air observations**. However all are well above the 370 ppm which is a reasonable value for this time and location, and all were **rejected**.

To calculate  $\Delta p\text{CO}_2$  we use the Global View  $\text{CO}_2$  data, extrapolated from the end of 2001 through the early part of 2002. The last observations in that file are for year 2001. A longterm trend is fitted to these observations, then extrapolated forward. Naturally, there is some uncertainty in this extrapolation, but it should be less than  $\pm 0.5$  ppm. This value goes into the "vco2\_air" and "gvvco2\_air" variables in the **L022sfc** database.

**1-e) Editing:**

The individual daily merged files were concatenated into rawdata.txt, and that file was edited to remove the beginning and ending periods before the first and after the last standard set. Also, this file was edited to remove periods where the sample set was incomplete, and where the system delivered meaningless data.

a. The TSG temperature was not reliable for most of this cruise. We use a linear regression to estimate SST from equilibration temperature. The equation is:

$$\text{Sea Surface Temperature} = -0.00682 \times \text{pCO}_2 \text{ Temperature} + 0.15$$

b. The system did not seem to recover properly from the standard runs, and the first five seawater observations after each set of standards were eliminated.

c. If the flow of air as recorded by the system fell below  $20 \text{ ml min}^{-1}$  we eliminated the observation.

d. There were 6 periods where the high standard flow stopped, and one where both it and the 251.79 ppm standard flow stopped. Where only the middle three standards, and Nitrogen, were available, we used the 3 middle standards fit to a quadratic response curve to calculate  $v\text{CO}_2$  from Licor millivolts. Where all 5 standards were available, we used all 5 and fit a 4<sup>th</sup> order response curve.

Of the **2,314 observations** of seawater  $\text{pCO}_2$  we **rejected 435, retaining 1,879 records**.

To create a **L022sfc.dbf** surface format file, we use only ACCEPTED  $\text{pCO}_2$  values, but all the observations are preserved in the **pco2data.dbf** database. We estimate the air value from the Globalview CO2database (as explained under 1-d) AIR data. The program **makeL022.prg** performs this process. The program also adds salinity from the edited salinity file **saldata.dbf** in the salinity subdirectory (see other data below).

#### **1-f) Other Data:**

Salinity: There is a program, **procsal.prg** in the subdirectory salinity which performs editing of the salinity data. The system uses a mean and standard deviation of 15 data points. There are five passes through the data. Three calculate mean and standard deviation, two perform edits. After each of the first 2 calculation passes, data points are rejected if outside 1 standard deviation. A minimum standard deviation of 0.02 is assigned. After the second editing pass (4th through the data), mean and standard deviation of the remaining data are calculated using only accepted values. Between accepted values the mean is unchanged. Finally two periods were rejected "by hand" due to very high noise. This file **saldata.dbf** is then used as the source for salinity in the master file **L022sfc.dbf**.

Wind speed units are meters seconds<sup>-1</sup>.

## 2. MEASUREMENTS OF pCO<sub>2</sub> IN SURFACE WATERS

### 2-a) The LDEO Underway System for Surface Water pCO<sub>2</sub> Measurements:

The system for underway measurements of pCO<sub>2</sub> in surface waters consists of a) a water-air equilibrator, b) a non-dispersive infra-red CO<sub>2</sub> gas analyzer and c) a data logging system. The measurement system is schematically shown in Fig. 1, and is similar with the one described in Bates et al. (1998). Each of these units and the data reduction procedures used will be described below.

Figure 1 - The underway pCO<sub>2</sub> system used for the measurements of pCO<sub>2</sub> in surface waters during the Southern Ocean JGOFS (AESOP) Program.

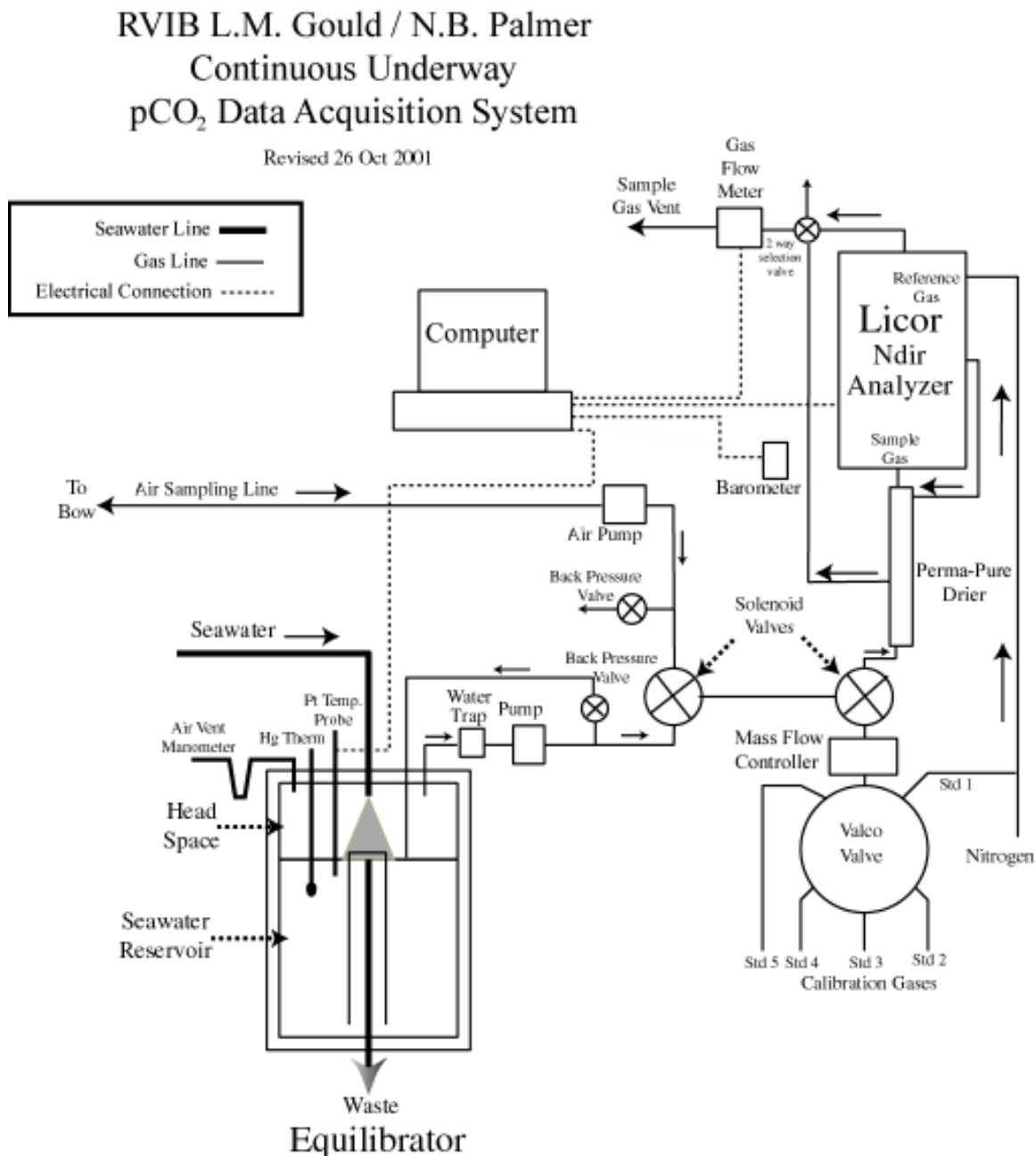

## **2-b) Water-air Equilibrator:**

The equilibrator has a total volume of about 30 liters and is equipped with a specially designed drain which maintains automatically the level of water in the equilibrator at a constant level at about half the height of the equilibrator leaving about 15 liters of headspace. Seawater from the ship's uncontaminated water line is continuously pumped into the equilibrator at a rate of about 10 liters/min, giving a mean residence time of water in the equilibrator of about 1.5 minutes. The headspace above the water serves as an equilibration chamber. A carrier gas (commonly marine air) is drawn into the chamber by a diaphragm pump, and exchanges CO<sub>2</sub> with a continuous flow of seawater sprayed into the chamber through a shower head. Because of large gas-water contact areas created by fine water droplets as well as gas bubbles in the pool of water, CO<sub>2</sub> equilibration between the carrier gas and seawater is achieved rapidly with a e-folding time of 2 to 3 minutes. Under normal operating conditions, the carrier gas in the equilibration chamber is pumped into the infra-red gas analyzer at a rate of about 50 ml/min. At this rate, the residence time of the carrier gas in the equilibration chamber is about 300 minutes, that is about 100 times as long as the equilibration time. Therefore, the carrier gas in the head space is always in equilibrium with water. The over all response time of the equilibrator system has been estimated to be of an order of several minutes. The large volume of water in the equilibrator is chosen in order to have a large thermal inertia of the equilibrator, so that the effects of room temperature changes on the equilibration temperature may be minimized. The temperature of water in the equilibrator is monitored continuously using a Guildline platinum resistance thermometer (readable to 0.05 °C) and recorded on the data logging computer. A calibrated mercury thermometer is also inserted in the equilibrator for testing the performance of the platinum thermometer.

At the gas intake end of the equilibrator, a flow indicator based on U-tube manometer is attached. This gives a visual confirmation for the fact that marine air is taken into the equilibration chamber at a desired flow rate. Since we operate the system with the equilibration chamber at the same pressure as the ambient room pressure, the total pressure, at which the gas was equilibrated, is measured using a precision electronic barometer (Setra Model 270, Action, MA) outside the equilibrator. This equilibration pressure is also logged on the computer.

The temperature and salinity of seawater at the in situ conditions were measured using a SeaBird Model SBE-21 thermosalinograph aboard the N. B. Palmer and a SIO/ODF thermosalinograph unit based on Neil Brown sensors aboard the R. Revelle. The precision of the report temperature data has been estimated to be about 0.005 °C.

## **2-c) Infra-red CO<sub>2</sub> Gas Analyzer:**

The equilibrated gas was passed through a water trap (to collect aerosols and condensates), mass flow controller and a reverse flow naphion dryer (PermaPure flushed with pure nitrogen gas) to remove water vapor (to a level of -20°C), and was introduced into the IR sample cell at a rate of about 50 ml/min for CO<sub>2</sub> determinations. A LI-COR infra-red gas analyzer (Model 6251, Lincoln, NB) was used. After about 2 minutes of

purging period, the gas flow was stopped and readings were recorded on the computer. Although an electronic circuit was provided by the manufacturer in order to linearize the CO<sub>2</sub> response, it exhibited a few inflexions that deviated from linearity by a few ppm. Therefore, we chose not to use the outputs from the linearization circuit supplied by the manufacturer. Instead, we used five standard gas mixtures (one pure nitrogen and four CO<sub>2</sub>-air mixtures) during the expeditions, and established response curves using the raw output from the analyzer. The CO<sub>2</sub> concentrations in the gas mixtures were calibrated using the SIO standards determined by C. D. Keeling's group using the manometric method. The concentrations of CO<sub>2</sub> in the standard gas mixtures were summarized above.

During normal operations, each of the standard gas mixtures was passed through the analyzer for 120 seconds at a rate of about 60 ml/min. This replaced the IR analyzer cell completely with the new gas. The flow was stopped for 10 seconds and then a millivolt reading from the analyzer was taken and recorded. Samples of equilibrated air and marine air were pumped through the analyzer for 120 seconds (2 minutes) at a rate of about 50 ml/min to purge the previous sample in the IR cell. The flow was stopped for 10 seconds and a reading for the analyzer output was recorded. This procedure was intended to eliminate errors due to fluctuations of the dynamic pressure within the IR cell by irregular gas flow rates. The slow flow rates used for samples were required for the removal of water vapor using the PermaPure membrane dryer. We analyze 20 seawater and two air samples between two sets of calibration runs using the five standard gases.

#### **2-d) Data Logging System:**

Our laptop records the following data and writes it via a serial port to the ship's RVDAS system.

Date,  
Time (GMT),  
Sample ID (standard gas cylinder numbers, seawater CO<sub>2</sub>, atmospheric CO<sub>2</sub>)  
Barometric pressure in the laboratory (to 0.1 mb)  
IR cell temperature,  
Gas flow rate in the IR cell (to 0.1 ml/min),  
Temperature of equilibration (to 0.01 °C),  
Analyzer output (millivolts to 0.1 mv)  
CO<sub>2</sub> concentration in dry gas sample (preliminary based on the last response curve), and  
pCO<sub>2</sub> (preliminary value based on the last response curve).

The ships RVDAS system adds several other data elements from various sensors and equipment. The list is:

Latitude, Longitude, Thermosalinograph temperature, thermosalinograph salinity, fluorometer voltage, wind speed, wind direction, and, barometric pressure.

**2-e) Data Reduction Procedures:**

The concentration of CO<sub>2</sub> in the sample was computed by the following way based on the millivolt reading and time of the reading. The millivolt reading taken for each of the five standard gases at the time of sample measurement was computed by linearly interpolating as a function of time using the readings taken before and after the respective standard gases were analyzed. This yields millivolt reading for each of the five standard gases at the time when the sample was analyzed. These five values were fit to a fourth-order polynomial equation (with five constants to be determined). This serves as the response curve. The CO<sub>2</sub> concentration in the sample was computed using the response curve that was established at the time of each sample analysis. This method has been demonstrated to yield more reliable CO<sub>2</sub> values compared with those computed, for example, using a least-squares fit of a quadratic or cubic functions to the five calibration points. The method described above yields atmospheric CO<sub>2</sub> values that are consistent with those reported for the South Pole and the Cape Grim by the Climate Monitoring and Diagnostics Laboratory/NOAA in Boulder, CO.

The partial pressure of CO<sub>2</sub> in seawater, (pCO<sub>2</sub>)<sub>sw</sub>, at the temperature of equilibration, T<sub>eq</sub>, in the unit of microatmospheres (µatm) was computed using the expression:

$$(pCO_2)_{sw} @ T_{eq} = (V_{CO_2})_{eq} \times (P_b - P_w), \dots \dots \dots [1]$$

- (V<sub>CO<sub>2</sub></sub>)<sub>eq</sub> = the mole fraction concentration (ppm) of CO<sub>2</sub> in the dried equilibrated carrier gas;
- P<sub>b</sub> = the barometric pressure (that is equal to the total pressure of equilibration) in atmospheres; and
- P<sub>w</sub> = the equilibrium water vapor pressure at T<sub>eq</sub> (°C) and salinity.

The water vapor pressure was computed using the following formulation;

$$P_w \text{ (atm)} = (1/760) \times (1 - 5.368 \times 10^{-4} \times \text{Sal}) \times \text{EXP}\{[0.0039476 - (1/TK)]/1.8752 \times 10^{-4}\}, \dots \dots [2]$$

where Sal is salinity in PSU measured using the ship's thermosalinograph, and TK is the temperature of equilibration in °K.

The (pCO<sub>2</sub>)<sub>sw</sub> at the in situ temperature, T<sub>in situ</sub>, was computed using a constant value of 0.0423 % per °C for the effect of temperature (Takahashi et al., 1993):

$$(pCO_2)_{sw} @ T_{in \text{ situ}} = (pCO_2)_{sw} @ T_{eq} \times \text{EXP}[0.0423 \times (T_{in \text{ situ}} - T_{eq})].$$

The value for T<sub>in situ</sub> is taken to be the seawater temperature measured by the ship's thermosalinograph at the time of pCO<sub>2</sub> measurements. T<sub>eq</sub> is generally warmer than T<sub>in situ</sub> by 0.5 ~ 0.8 °C. Hence the temperature correction is normally less than 3% of pCO<sub>2</sub> values.

The over all precision of the reported  $p\text{CO}_2\text{sw}$  values has been estimated to be about  $\pm 1.5$  uatm.

### 3. MEASUREMENTS OF $p\text{CO}_2$ IN THE ATMOSPHERE

#### 3-a) Measurements:

The air measurement system is shown schematically in Fig. 1. Uncontaminated marine air samples were collected about 10 m above the sea surface using a DEKORON tubing (1/4" i.d., Calco Inc., PA), a thin-wall aluminum tubing protected by plastic casing. The intake was located at the middle of the foremast about 10 m above the sea surface. A KNF Neuberger air pump that was located near the IR analyzer was used to pump air through the tubing and into the IR analyzer. Even when air samples were not analyzed, the pump was on all the time to keep the air flowing through the sampling line. For the analysis, the air sample was passed through a water trap and a drying column to remove water vapor (the same PermaPure column as used for the equilibrated gas) and introduced into the IR cell for  $\text{CO}_2$  analysis at a rate of about 50 ml/min. After 2 minutes of purging the cell, the flow was stopped for 10 seconds and the IR millivolt output reading was recorded.

#### 3-b) Data Processing:

The partial pressure of  $\text{CO}_2$  in the air,  $(p\text{CO}_2)\text{air}$ , was computed in the unit of microatmospheres ( $\mu\text{atm}$ ) in the same way as that for seawater using Eq. [3] below:

$$(p\text{CO}_2)\text{air} = (V_{\text{CO}_2})\text{air} \times (P_b - P_w), \dots \dots \dots [3]$$

- $(V_{\text{CO}_2})\text{air}$  = the mole fraction concentration (ppm) of  $\text{CO}_2$  in the dried air sample;
- $P_b$  = the barometric pressure at sea surface in atmospheres; and
- $P_w$  = the equilibrium water vapor pressure at  $T_{\text{in situ}}$  ( $^{\circ}\text{C}$ ) and salinity given by Eq. [2].

The precision of the atmospheric  $p\text{CO}_2$  values have been estimated to be about  $\pm 1$   $\mu\text{atm}$ .



#### **4. REFERENCES CITED**

Bates, N. R., Takahashi, T., Chipman, D. W. and Knapp, A. H. (1998). Variability of  $p\text{CO}_2$  on diel to seasonal time scales in the Sargasso Sea. *Jour. Geophys. Res.*, 103, 15567-15585.

$\text{CO}_2$  Group, Lamont-Doherty Earth Observatory. (1999) “ $p\text{CO}_2$  Equilibrator Users Manual”, LDEO of Columbia University, Palisade, NY, pp.10.

Takahashi, T., Olafsson, J., Goddard, J., Chipman, D. W. and Sutherland, S. C., (1993). Seasonal variation of  $\text{CO}_2$  and nutrients in the high-latitude surface oceans: A comparative study. *Global Biogeochemical Cycles*, 7, 843-878.