

REPORT OF UNDERWAY $p\text{CO}_2$ MEASUREMENTS IN SURFACE WATERS
AND THE ATMOSPHERE DURING February - March 2017

R/V Laurence M. Gould 17/2

S. C. Sutherland, Timothy Newberger, Taro Takahashi, and Colm Sweeney
Lamont-Doherty Earth Observatory of Columbia University
Palisades, NY 10964

19 April 2017

Part 1 - Data Processing and Quality Control.

1. General

a) Cruise Overview

1) This was another Palmer Station resupply mission and included several days of research in the Antarctic Peninsula. The ship departed Punta Arenas on **15 February** and returned on **20 March 2017**. Our system performed reasonably well with problems with flow of the standard and sample gases.

2) The $p\text{CO}_2$ data for this cruise was processed to account for the delay between the remote temperature probe near the sea water suction and our system. The remote probe temperature was offset one time interval.

R/V L.M. Gould Cruise 17/2

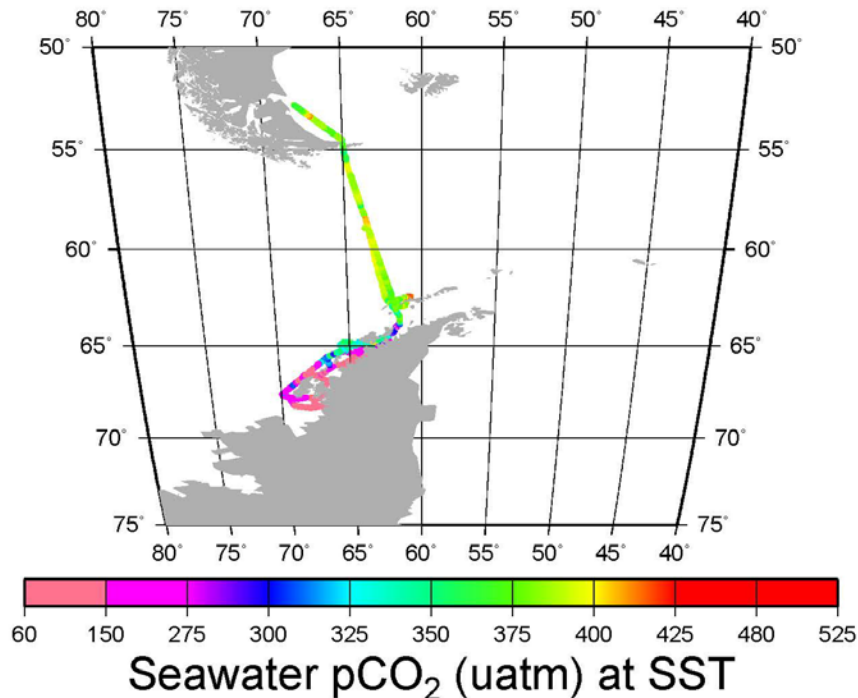

b) Data Overview

1) The **pCO₂** system performed well except for several periods where the flow of the sample and standard gases were interrupted.

2) We use the one scan offset to account for the delay between the SST observation and the arrival of that parcel of water into our equilibrator. There were a few brief periods of water flow interruption that have been edited out.

3) The SBE 38 probe was used for equilibration temperature.

4) The **atmospheric pCO₂** observations were unusable.

4) The **chlorophyll A** data from the WetLabs Fluorometer is also appears to be fine.

2. Standards:

Cylinder Concentration (ppm)

Nitrogen (UHP) 0.0

CA08543 113.33

CA08560 391.87

CA08539 242.45

CA07203 508.07

CA08545 371.11

A 4th order calibration curve is used with 5 standards, not including the Nitrogen, as described in Section 2. The calibration curves are also plotted in Section 4.

Standards flow for about 120 seconds before an observation is made.,

3. Details of pCO₂ data.

a. Of the total of **10,906** observations were made, **488** were rejected, leaving **10,418** valid observations.

4. Details of temperature data.

Temperature in the equilibration vessel is measured with two instruments. The primary instrument is a Seabird model 38 temperature probe. Its calibration is maintained by the manufacturer. Our original instrument use Guildline platinum resistance thermometer (readable to 0.05 °C and regularly calibrated against a mercury thermometer traceable to N.I.S.T.) and recorded on the data-logging computer.

5. Details of Salinity data.

The salinities must be considered uncalibrated, but our previous experience shows very good agreement with Autosal determinations. Errors are generally less than 0.05 units on the Practical Salinity Scale.

6. Details of the air data

The air data is much too noisy to be usable. I did not attempt to edit these data, and they are unreported.

Part 2 Description of Instrumentation

a) The LDEO Underway System for Surface Water pCO₂ Measurements:

The underway pCO₂ measurement system for surface waters consists of a) a water-air equilibrator, b) an analyzer system based on a non-dispersive infra-red CO₂ gas analyzer, c) sample pumps, d) 5 calibration standards and e) a data logging system. The measurement system is schematically shown in Fig. 1, and is similar with the one described in Bates et al. (1998). Each of these units and the data reduction procedures used will be described below.

Figure 2: Diagram of the underway pCO₂ system used for surface water pCO₂ measurements during NBP04-03 which is essentially identical to the Gould System.

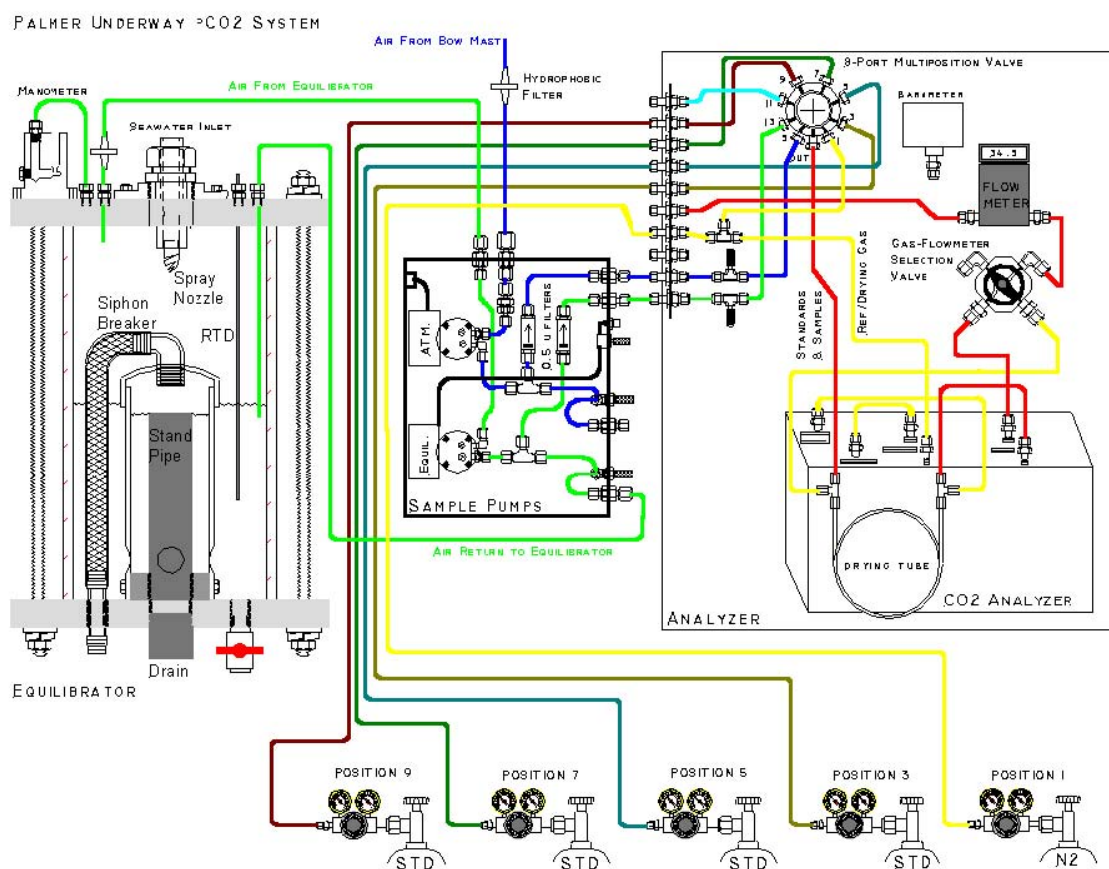

b) Water-air Equilibrator:

The equilibrator has a total volume of about 30 liters and is equipped with a standpipe that is isolated from the headspace and automatically maintains a constant water level at about half the height of the equilibrator leaving about 15 liters of headspace (Figure 2).

Seawater from the ship's uncontaminated water line is continuously pumped into the equilibrator at a rate of about 10 liters/min, giving a mean residence time of water in the equilibrator of about 1.5 minutes. The headspace above the water serves as an equilibration chamber. A carrier gas (commonly marine air) is continuously circulated to and from the head space in a closed loop by a diaphragm pump, and exchanges CO₂ with the continuous flow of seawater sprayed into the chamber through a spiral cone spray nozzle. Because of large gas-water contact areas created by fine water droplets as well as gas bubbles in the pool of water, CO₂ equilibration between the carrier gas and seawater is achieved rapidly with a e-folding time of 2 to 3 minutes. Under normal sampling conditions, about 50 ml/min of this sea water equilibrated air is directed into the infra-red gas analyzer. The air drawn for analysis is replaced by a controlled leak into the equilibrator through the water manometer. At this rate, the residence time of the carrier gas in the equilibration chamber is about 300 minutes, that is about 100 times as long as the equilibration time. Therefore, the carrier gas in the head space should always be in equilibrium with the seawater. The over all response time of the equilibrator system has been estimated to be of an order of several minutes. The large volume of water in the equilibrator was chosen to provide a large thermal inertia in the equilibrator, so that the effects of room temperature changes on the equilibration temperature may be minimized. The temperature of water in the equilibrator is monitored continuously using a Guildline platinum resistance thermometer (readable to 0.05 °C and regularly calibrated against a mercury thermometer traceable to N.I.S.T.) and recorded on the data-logging computer.

The water manometer is attached to the gas intake end of the equilibrator (Figure 2) and provides a visual confirmation that marine air is being returned to the equilibration chamber at the same flow rate that it is being diverted to the CO₂ analyzer. The manometer also isolates the equilibrator head space from free exchange with the ambient marine air. The low head of the water manometer ensures that the equilibration chamber pressure is nearly identical to ambient atmospheric pressure. The total pressure at which the gas was equilibrated, can then be measured outside the equilibrator using a precision electronic barometer (Setra Model 270, Action, MA). This equilibration pressure is also logged on the computer.

The temperature and salinity of seawater at the *in situ* conditions were measured using a SeaBird Model SBE-21 thermosalinograph aboard the N. B. Palmer and a SIO/ODF thermosalinograph unit based on Neil Brown sensors aboard the R. Revelle. The precision of the reported temperature data has been estimated to be about 0.005 °C.

c) **Infra-red CO₂ Gas Analyzer:**

The equilibrated gas was passed through a water trap (to collect condensate,) and, and a reverse flow naphion dryer (PermaPure flushed with pure nitrogen gas) to remove water vapor (to a level of -20 °C dewpoint), and was introduced into the IR sample cell at a rate of about 50 ml/min for CO₂ determinations. A LI-COR infra-red gas analyzer (Model 6251, Lincoln, NB) was used. After a 2-minute purging period, the gas flow was stopped and readings were recorded on the computer. Although the CO₂ analyzer has an electronic circuit to linearize the CO₂ response, it exhibited a few inflexions that deviated

from linearity by a few ppm. Therefore, the pCO₂ system has been designed to use the raw voltage output of the CO₂ analyzer to establish our own calibration curves using five standard gas mixtures (one pure nitrogen and four CO₂-air mixtures). The CO₂ concentrations in the gas mixtures were calibrated using the SIO standards determined by C. D. Keeling's group using the manometric method. The concentrations of CO₂ in the standard gas mixtures were summarized above.

During normal operations approximately every 75 minutes each of the standard gas mixtures was passed through the analyzer for 120 seconds at a rate of about 60 ml/min. This flow rate and time was redundantly sufficient to completely purge the IR analyzer cell with the new gas. The flow was stopped for 10 seconds to allow the pressure in the cell to equilibrate to atmospheric pressure and the average of 20 separate millivolt readings from the analyzer was recorded. Following the five standard gases, samples of seawater-equilibrated air and ambient marine air were pumped through the analyzer for 120 seconds (2 minutes) each at rates of about 50 ml/min and 60 ml/min respectively to purge the previous sample in the IR cell. The flow was stopped for 10 seconds and the average of 20 separate millivolt readings from the analyzer was recorded. This procedure was intended to eliminate errors due to fluctuations of the dynamic pressure within the IR cell by irregular gas flow rates. The relatively slow flow rates used for seawater-equilibrated air samples were required for the removal of water vapor using the PermaPure membrane dryer. We analyze 30 seawater-equilibrated air samples and 5 ambient marine air samples between two sets of calibration runs using the five standard gases.

d) Data Logging System:

The following values were recorded on a laptop computer. The sample locations were derived from the ships Global Positioning System (GPS). The CO₂ readings for seawater equilibrated air samples were recorded approximately every 3 minutes, and those for the standard gas mixtures approximately every 90 minutes.

Time/Date stamp (GMT),

CO₂ analyzer voltage output (to 0.1 mv)

Analyzer cell temperature (to 0.1 C)

Barometric pressure (pCO₂ system barometer) (to 0.1 mbar)

CO₂ concentration (to 0.1 ppm, preliminary value based on the last response curve)

Equilibrator temperature (to 0.01 °C)

pCO₂ (uatm, preliminary value based on the last response curve)

Gas flow rate (to 0.1 cc/min)

Selector valve position (integer)

Sample ID (standard gas cylinder numbers, seawater CO₂, atmospheric CO₂)

The ships RVDAS system adds several other data elements from various sensors

and equipment including: Latitude, Longitude, Thermosalinograph temperature, thermosalinograph salinity, fluorometer voltage, wind speed, wind direction, barometric pressure (at ships instrument mast), water flow in the uncontaminated seawater line.

e) Data Reduction Procedures:

The concentration of CO₂ in the sample was computed in the following manner based on the millivolt reading and time of the reading. The millivolt reading taken for each of the five standard gases at the time of sample measurement was computed by linearly interpolating as a function of time using the readings taken before and after the respective standard gases were analyzed. This yields an interpolated millivolt reading for each of the five standard gases at the time when the sample was analyzed. These five values were fit to a fourth-order polynomial equation (with five constants to be determined). This serves as the response curve. The CO₂ concentration in the sample was computed using the response curve that was established at the time of each sample analysis. This method has been demonstrated to yield more reliable CO₂ values compared with those computed, for example, using a least-squares fit of a quadratic or cubic functions to the five calibration points. The method described above yields atmospheric CO₂ values that are consistent (within 1.5 ppm) with those reported for the South Pole and the Cape Grim by the Climate Monitoring and Diagnostics Laboratory/NOAA in Boulder, CO.

The partial pressure of CO₂ in seawater, (pCO₂)_{sw}, at the temperature of equilibration, Teq, in the unit of microatmospheres (µatm) was computed using the expression:

$$(pCO_2)_{sw} @ Teq = (VCO_2)_{eq} \times (P_{eq} - P_w), \dots \dots \dots [1]$$

(VCO₂)_{eq} = the mole fraction concentration (ppm) of CO₂ in the dried equilibrated carrier gas;
 Peq = the barometric pressure (that is equal to the total pressure of equilibration) in atmospheres; and
 Pw = the equilibrium water vapor pressure at Teq (°C) and salinity.

The water vapor pressure was computed using the following formulation;

$$P_w \text{ (atm)} = (1/760) \times (1 - 5.368 \times 10^{-4} \times \text{Sal}) \times \text{EXP}\{[0.0039476 - (1/TK)]/1.8752 \times 10^{-4}\}, \dots \dots [2]$$

where Sal is salinity on the Practical Salinity Scale and measured using the ship's thermosalinograph, and TK is the temperature of equilibration in °K.

The (pCO₂)_{sw} at the *in situ* temperature, T *in situ*, was computed using a constant value of 0.0423 % per °C for the effect of temperature (Takahashi et al., 1993):

$$(pCO_2)_{sw} @ Tin\ situ = (pCO_2)_{sw} @ Teq \times EXP[0.0423 \times (Tin\ situ - Teq)].$$

The value for *Tin situ* is taken to be the seawater temperature measured by the ship's thermosalinograph at the time of pCO_2 measurements. Teq is generally warmer than *Tin situ* by $0.5 \sim 0.8$ °C. Hence the temperature correction is normally less than 3% of pCO_2 values.

The over all precision of the reported $(pCO_2)_{sw}$ values has been estimated to be about ± 1.5 uatm.

f) Atmospheric Measurements:

The air measurement system is also shown schematically in Fig. 1. Uncontaminated marine air samples were collected about 10 m above the sea surface using a 1/4" i.d. thin-walled aluminum tubing protected by an exterior plastic casing and an internal plastic film lining (Synflex, Calco Inc., PA). The air intake was located at the middle of the foremast about 10 m above the sea surface. A KNF Neuberger air pump located near the IR analyzer was used to pump air through the tubing and into the IR analyzer. Even when air samples were not analyzed, air was continually flowing through the sampling line to continuously purge the long Synflex tubing with fresh marine air. For analysis, the air sample was passed through a 0.5 micron filter to remove aerosols and a drying column to remove water vapor (the same PermaPure column as used for the seawater-equilibrated air) and introduced into the IR cell for CO_2 analysis at a rate of about 60 ml/min. For each sample the cell was purged for 120 seconds, the flow was stopped for 10 seconds and the average of 20 IR millivolt output readings was recorded on the computer.

g) Atmospheric Data Processing:

The partial pressure of CO_2 in the air, $(pCO_2)_{air}$, was computed in the unit of microatmospheres (μatm) in the same way as that for seawater using Eq. [3] below:

$$(pCO_2)_{air} = (Vco_2)_{air} \times (Pb - Pw), \dots \dots \dots [3]$$

$(Vco_2)_{air}$ = the mole fraction concentration (ppm) of CO_2 in the dried air sample;

Pb = the barometric pressure at sea surface in atmospheres; and

Pw = the equilibrium water vapor pressure at *Tin situ* (°C) and salinity given by Eq. [2].

The precision of the atmospheric pCO_2 values have been estimated to be about ± 1 μatm .

Part 3 - References

Bates, N. R., Takahashi, T., Chipman, D. W. and Knapp, A. H. (1998). Variability of $p\text{CO}_2$ on diel to seasonal time scales in the Sargasso Sea. *Jour. Geophys. Res.*, 103, 15567-15585.

CO_2 Group, Lamont-Doherty Earth Observatory. (2004) "Underway $p\text{CO}_2$ System Users Manual", LDEO of Columbia University, Palisade, NY, pp.23.

Takahashi, T., Olafsson, J., Goddard, J., Chipman, D. W. and Sutherland, S. C., (1993). Seasonal variation of CO_2 and nutrients in the high-latitude surface oceans: A comparative study. *Global Biogeochemical Cycles*, 7, 843-878.

PART 4 - Graphics

List of Figures:

Maps showing the location of each seawater $p\text{CO}_2$ and SST value with the data point assigned a color based on an indicated color palette.

3-panel time series of various parameters, five each for the southbound and northbound legs. Northbound has been deleted from the final file.

A time series showing salinity data with editing.

Part 5 - Program Listings

These listings provide detailed documentation of processes applied to the data, including the calculation of a reponse curve, editing, and certain quality control operations.