

Earthquake Location and Tomography with Differential Traveltime Data

by William Menke
L.D.E.O

acknowledging the contributions of

David Schaff
L.D.E.O

Felix Waldhauser
L.D.E.O.

and the late
Sigurdur Rognvaldsson
Icelandic Meteorological Office

What you can measure:

arrival times of P and S
waves from an earthquake
observed at a station

*What you want to learn
when you locate an earthquake*

the location (x, y, z) and
origin time T_0 of the earthquake

and when you do tomography

the P velocity $V_p(x, y, z)$
and S velocity $V_s(x, y, z)$
of the earth

arrival time

not the same as

a travel time !

A car arrived in town at 1 PM
traveling at 60 m.p.h.

Where did it start?

*A car arrived in town after
traveling an hour at 60 m.p.h.*

Where did it start?

Vs correlates strongly with Vp:

$$V_p = \text{sqrt}[(k + 1.33 \mu) / \rho]$$

$$V_s = \text{sqrt}[\mu / \rho]$$

the ratio V_p/V_s has a fairly
limited range of values

most rocks $1.7 < V_p/V_s < 1.8$

partially molten rocks

V_p/V_s can be as high as 2.0

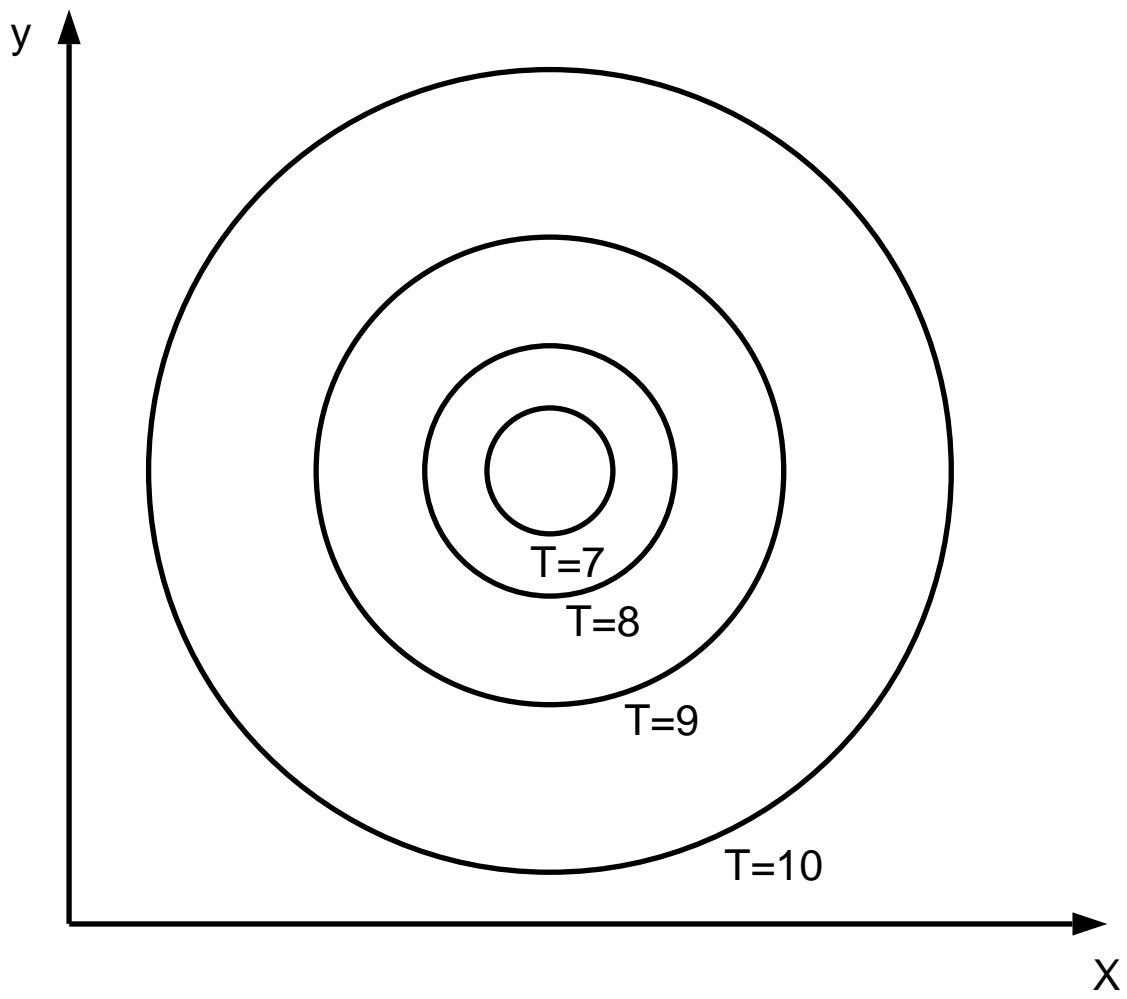

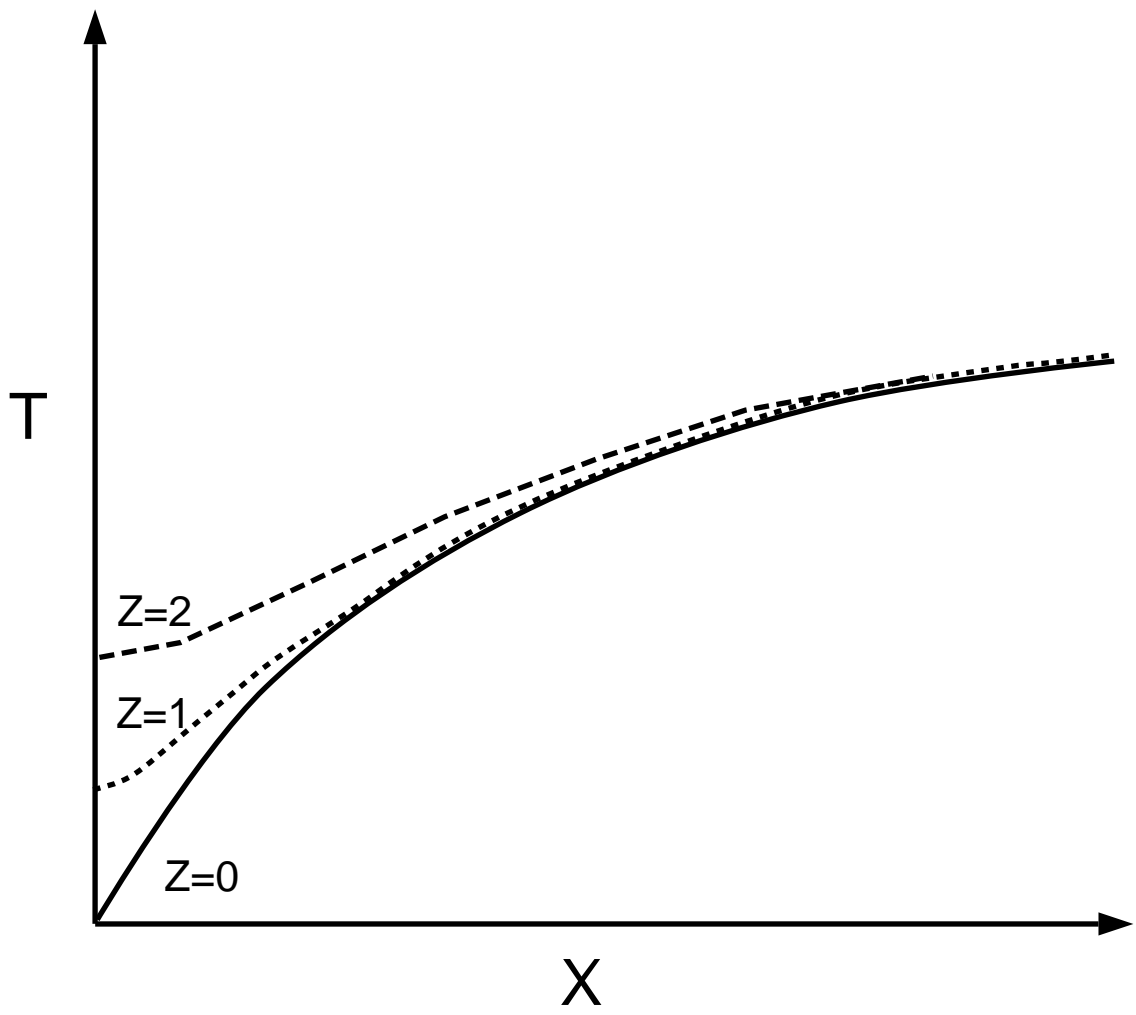

standard arrival time T_{pi}

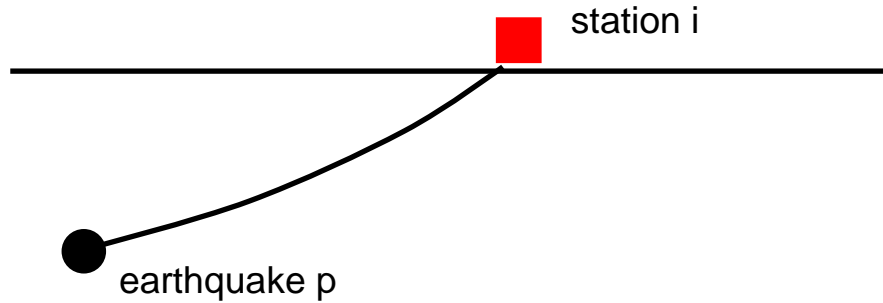

differential arrival time DT_{pqi}

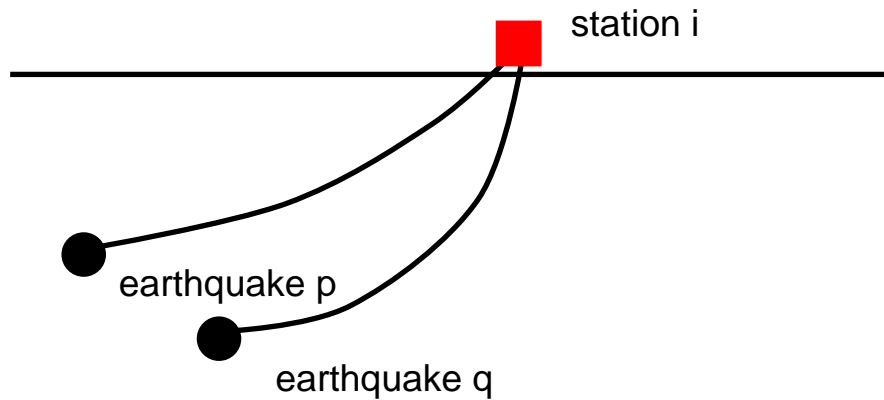

Disadvantages in using only

$$DT_{pqi} = T_{pi} - T_{qi}$$

- 1) loss of information about mean origin times

$$T_{pi} = TT_{pi} + T_{opi}$$

$$T_{qi} = TT_{qi} + T_{oqi}$$

$$DT_{pqi} = (TT_{pi} - TT_{qi}) - (T_{opi} - T_{oqi})$$

- 2) subtraction amplifies noise

$$\text{var}(DT_{pqi}) = \text{var}(T_{pi}) + \text{var}(T_{qi})$$

- 3) Weird correlations

$$DT_{pqi} = DT_{pri} - DT_{qri}$$

Advantages in using only

$$DT_{pqi} = T_{pi} - T_{qi}$$

1) use cross-correlation

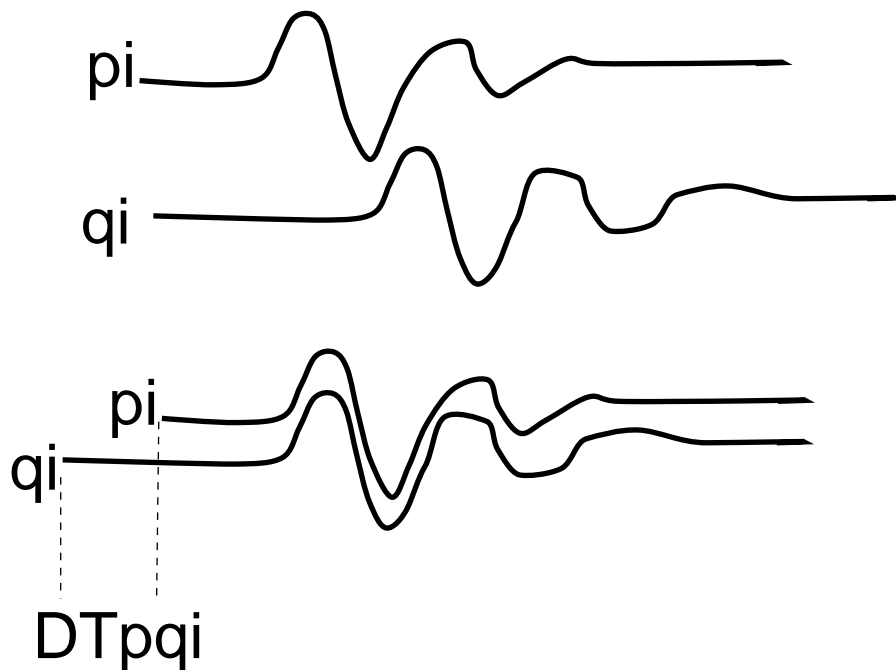

2) cancellation of near-station velocity model errors lead to better predictions of traveltime

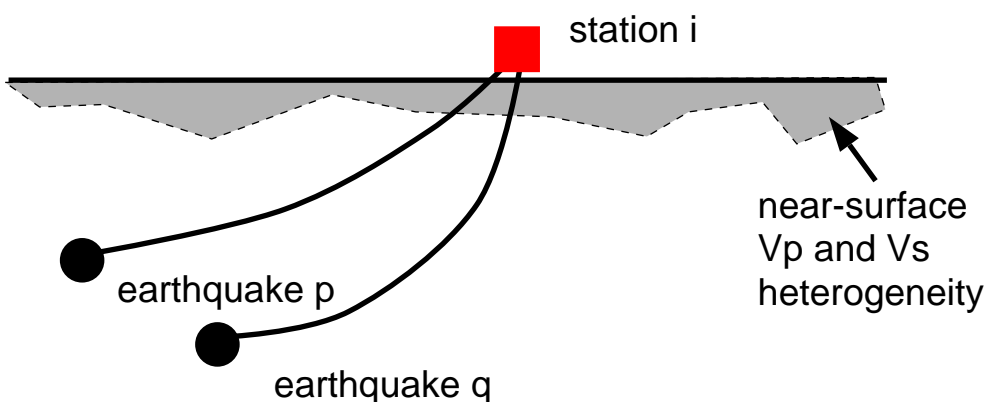

a.

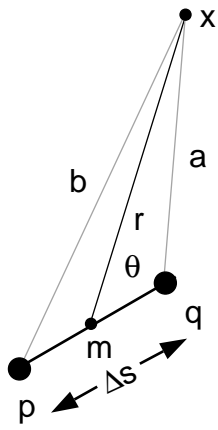

b.

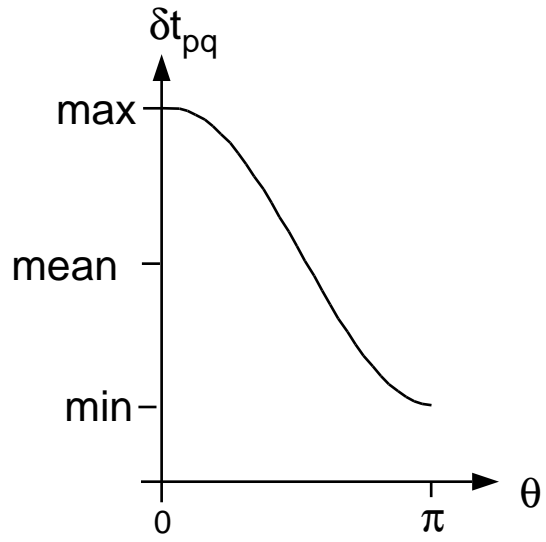

c.

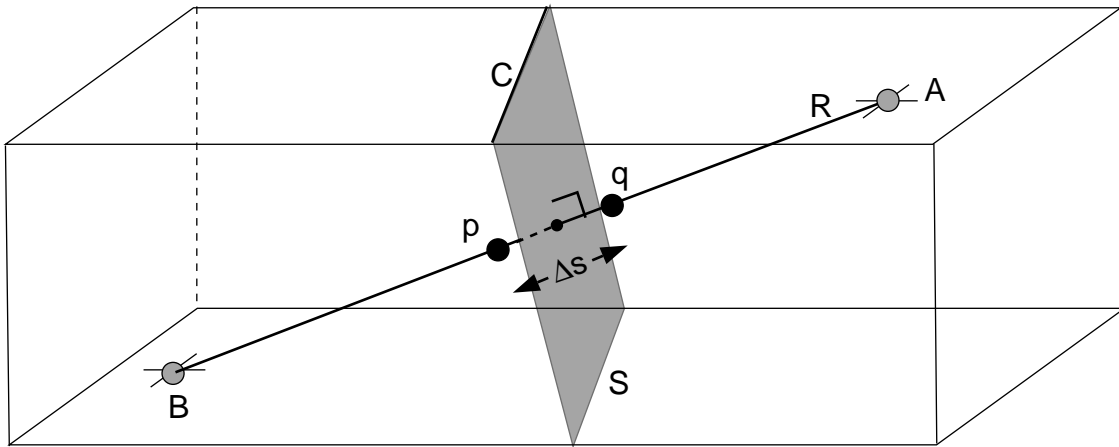

d.

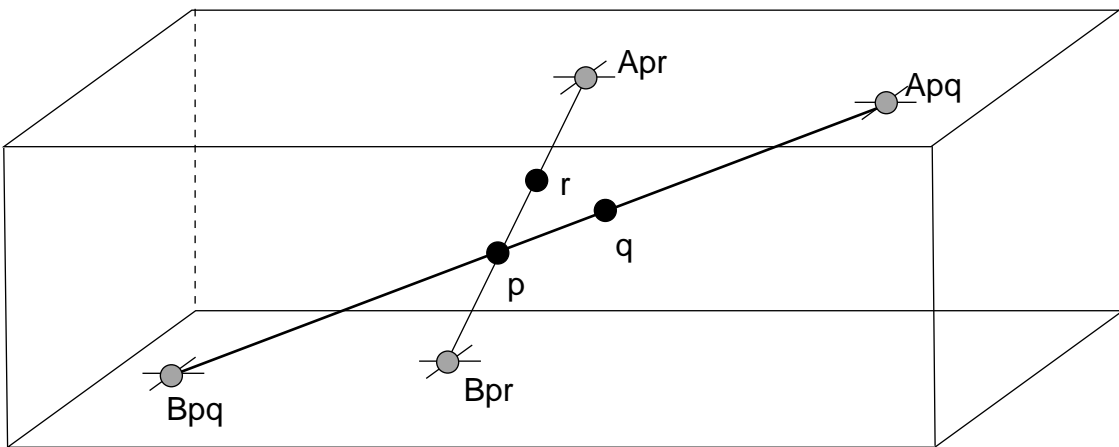

a.

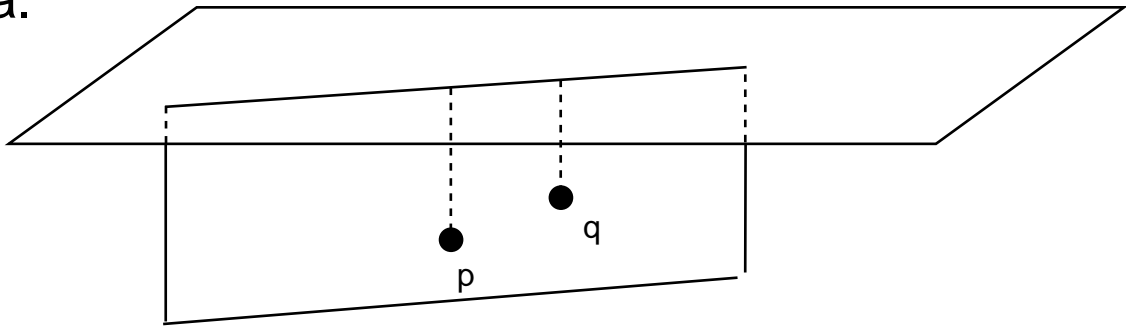

b.

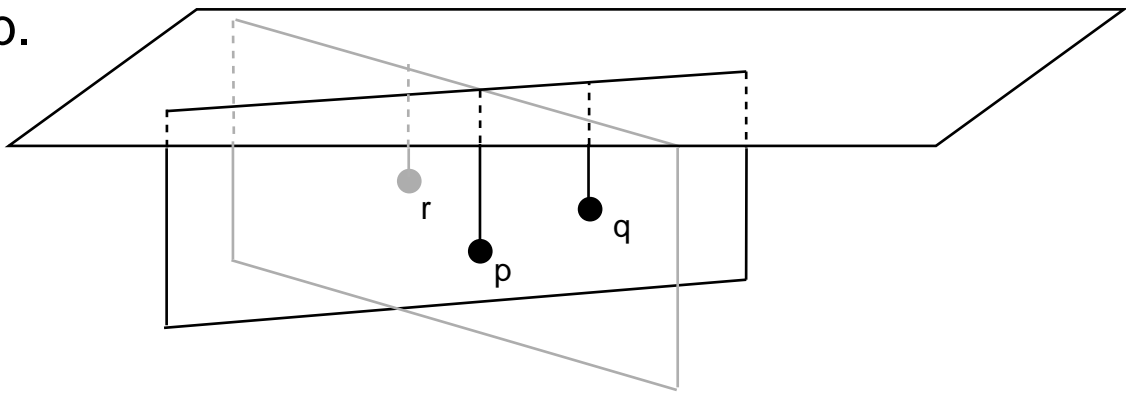

a.

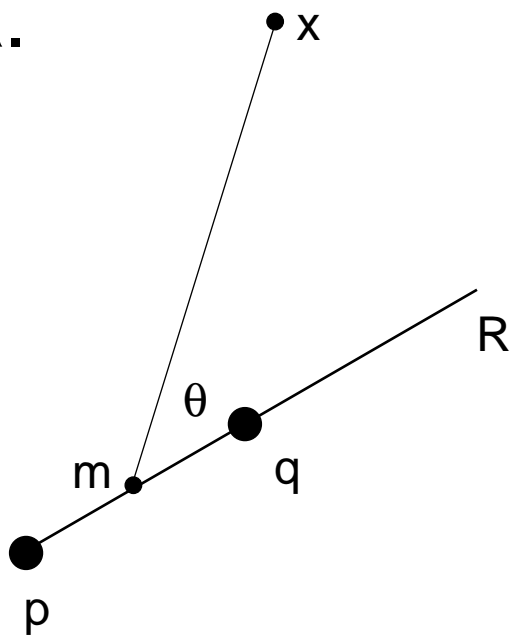

b.

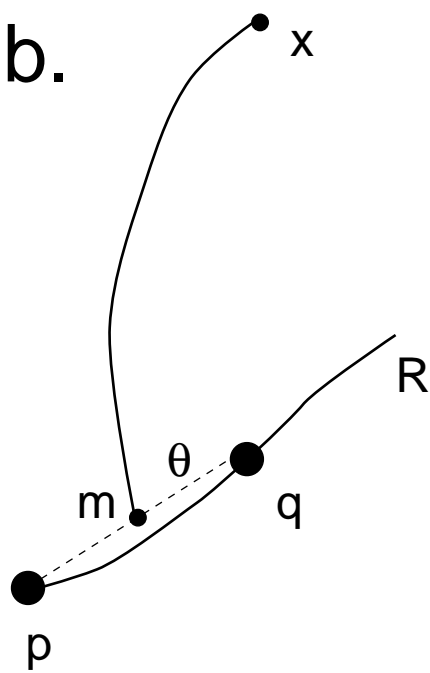

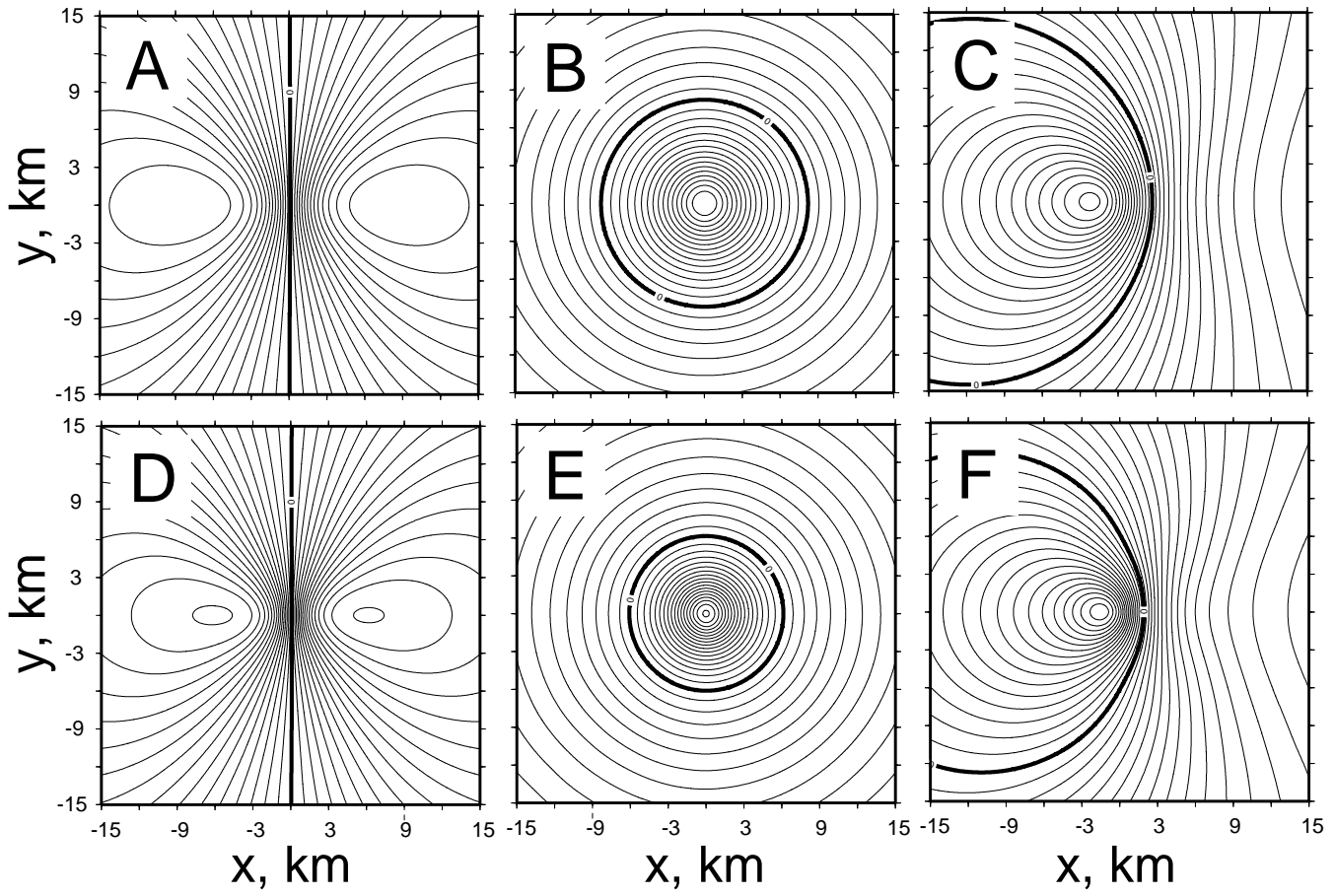

magnitudes: 2.7 & 2.5

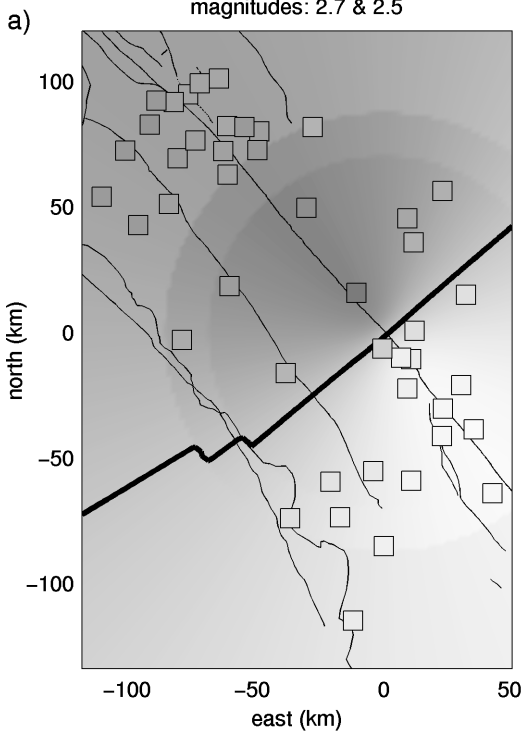

magnitudes: 3.2 & 3.1

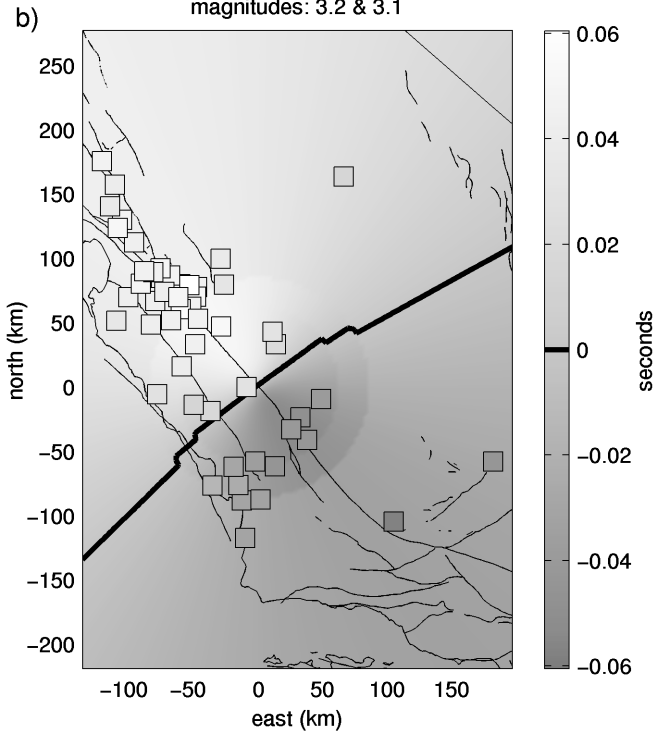

magnitudes: 5.0 & 4.5

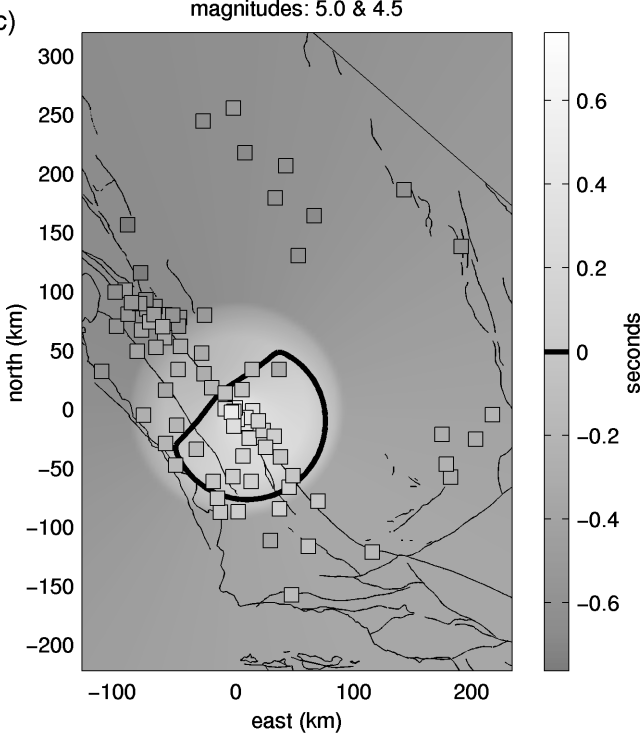

magnitudes: 5.0 & 5.0

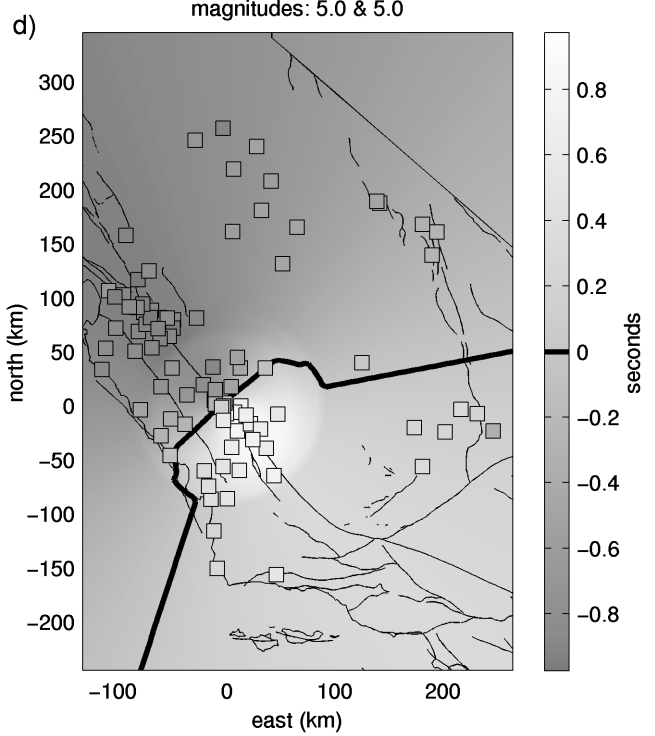

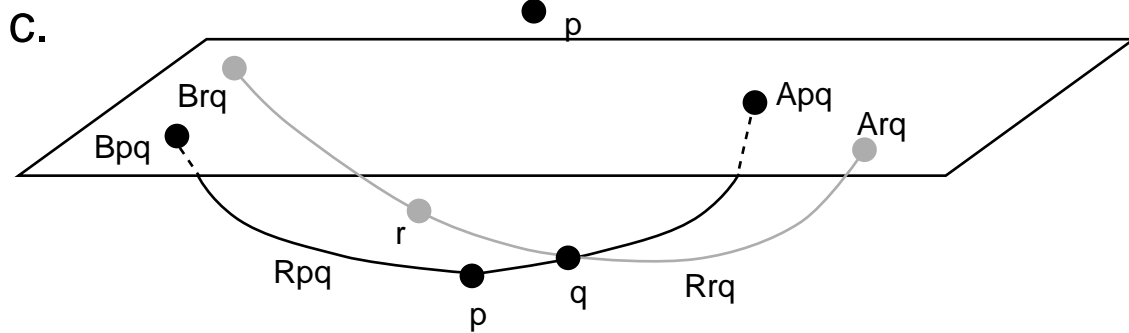
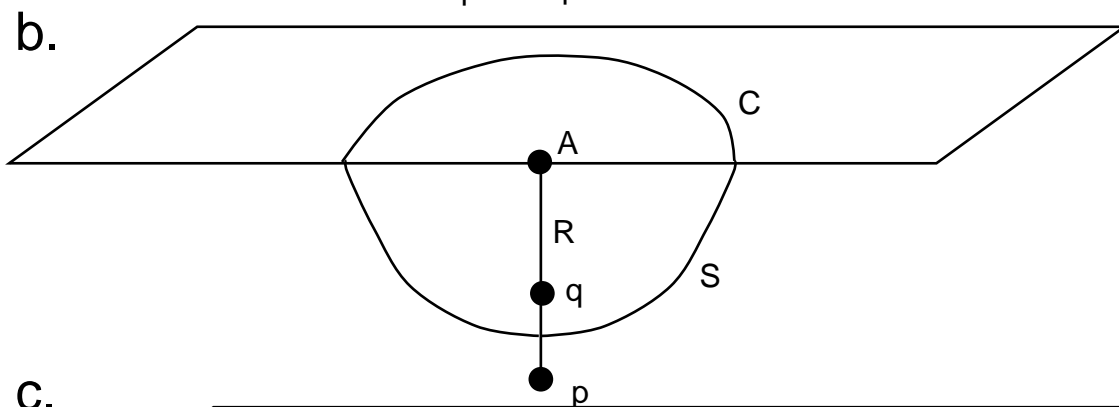
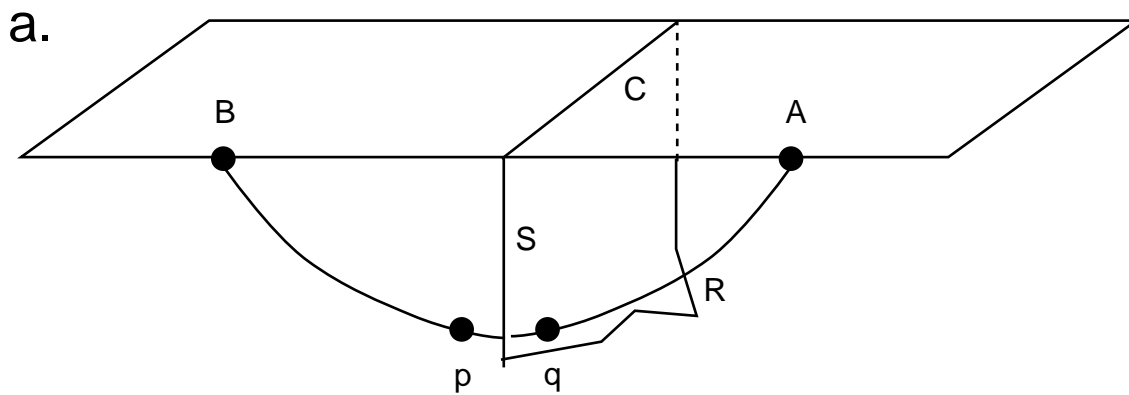

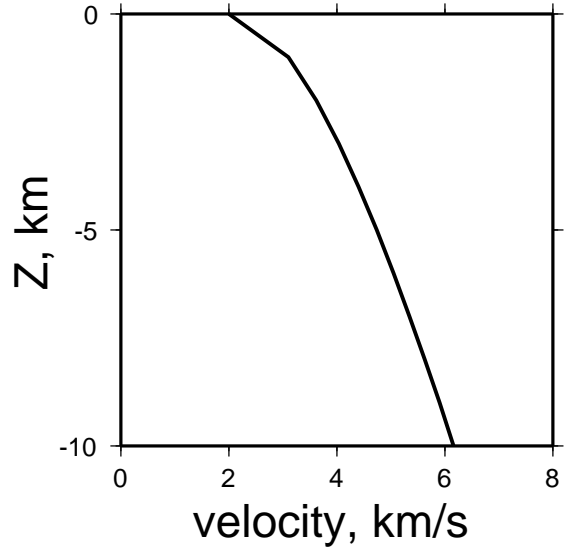
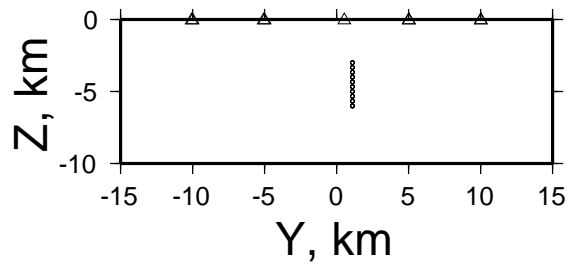
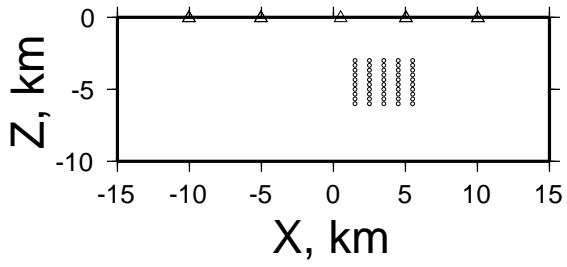
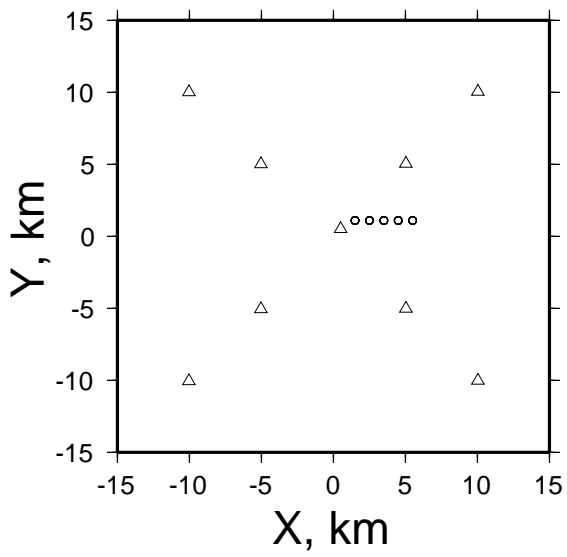

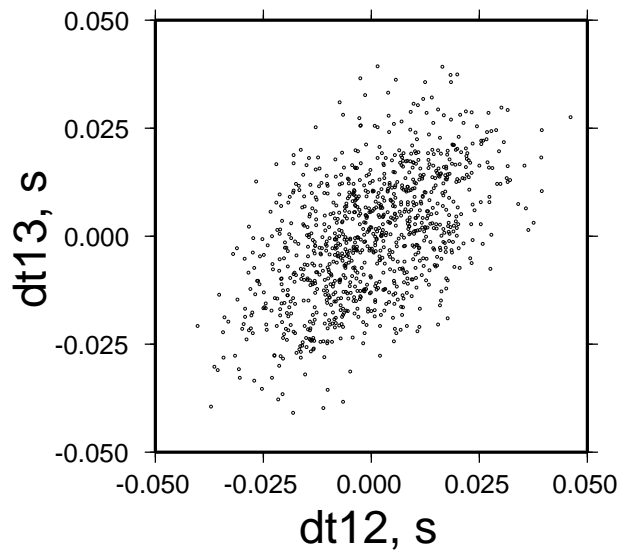
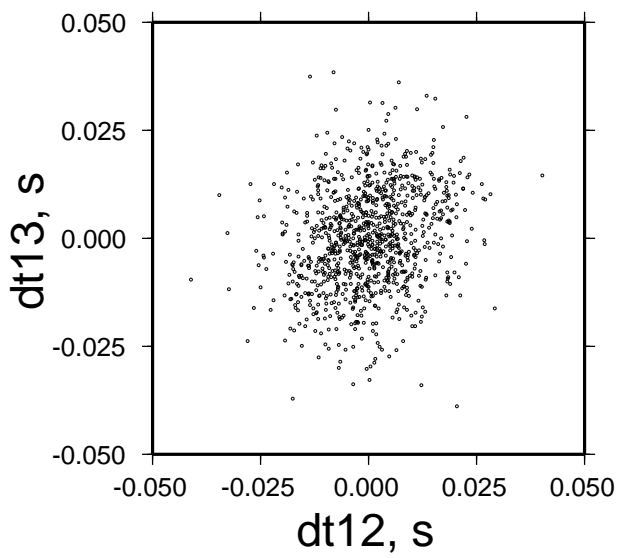
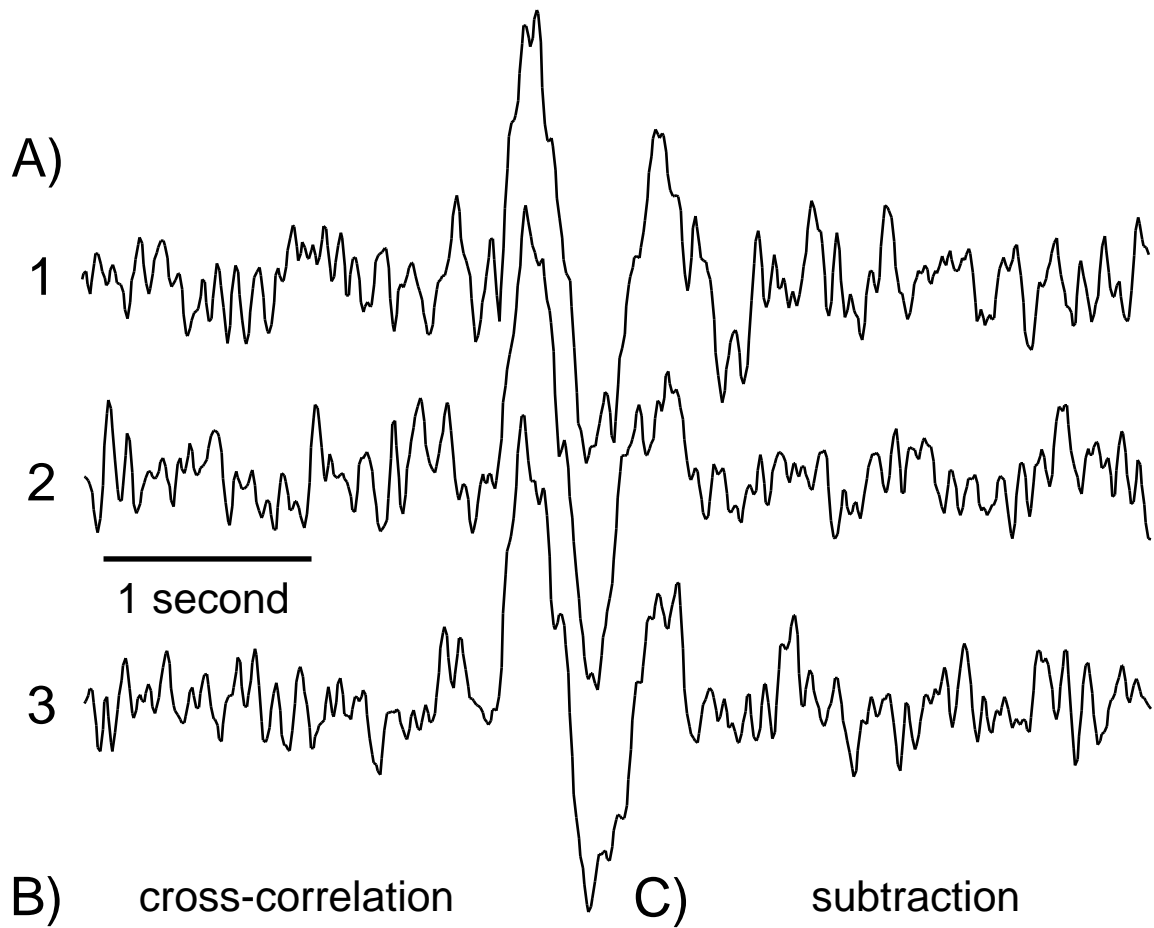

A) Absolute Locations

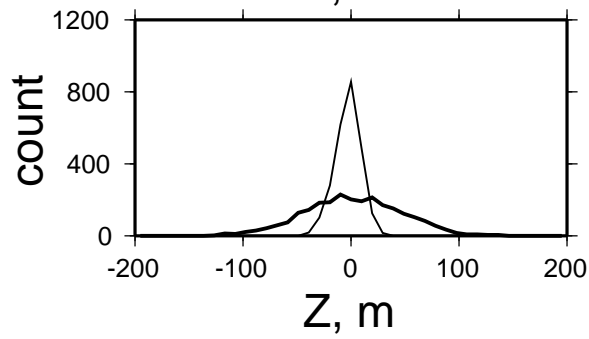
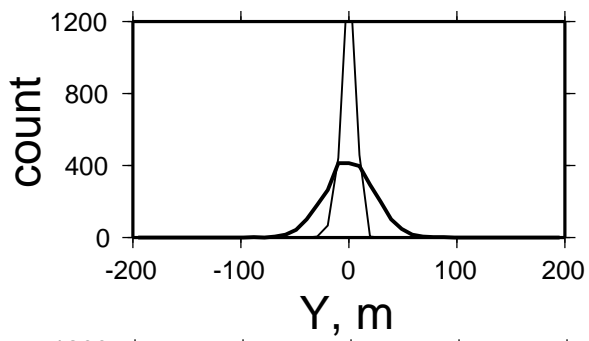
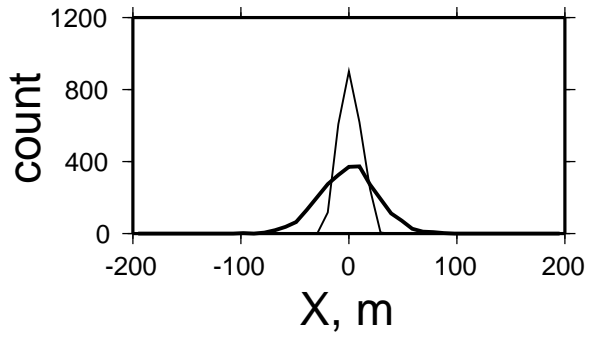

B) Nearest Neighbor Distances

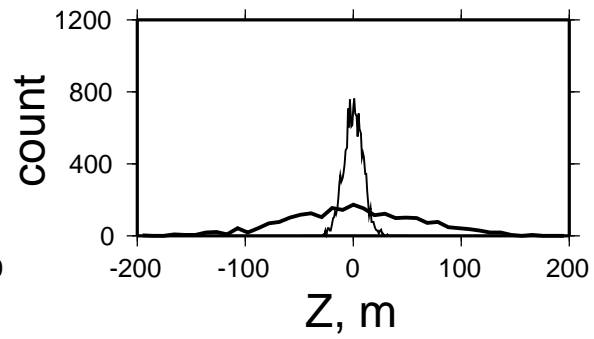
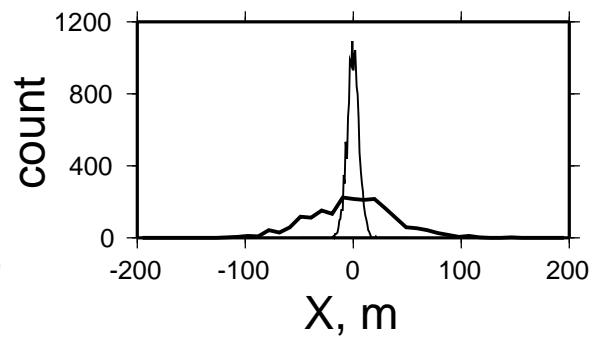

Near-Station Heterogeneities

A) Absolute Locations

B) Nearest Neighbor Distances

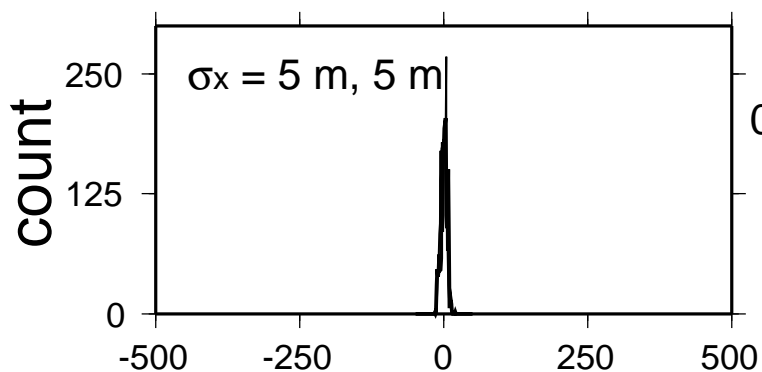

σ_v
0.01 km/s

ΔT
0.015 s

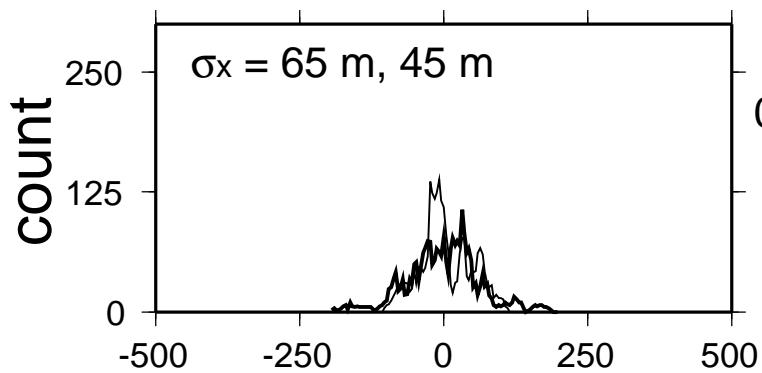
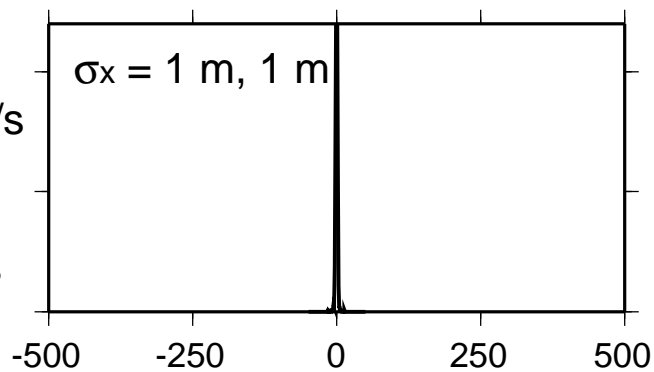

σ_v
0.1 km/s

ΔT
0.15 s

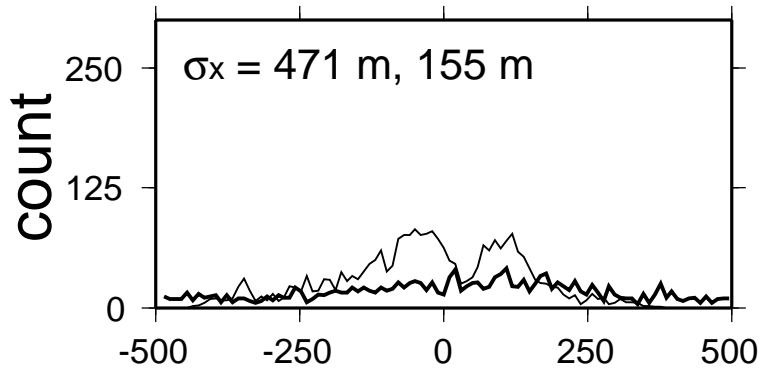
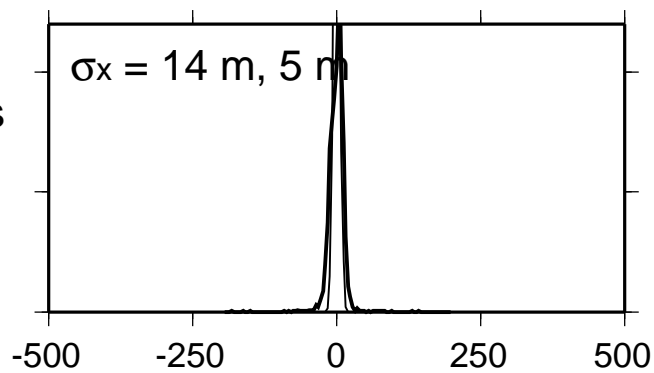

σ_v
1 km/s

ΔT
1.26 s

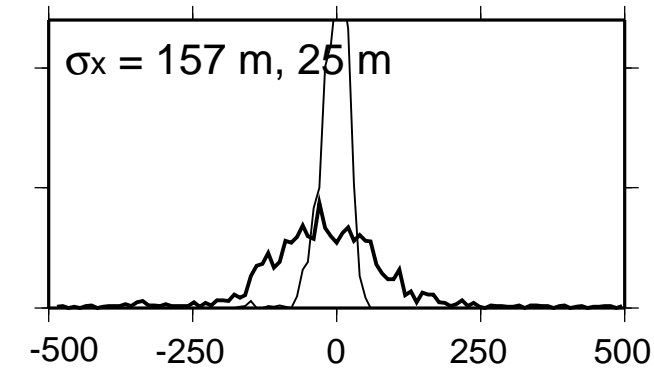

x, m

x, m

Volume Heterogeneities

A) Absolute Locations

B) Nearest Neighbor Distances

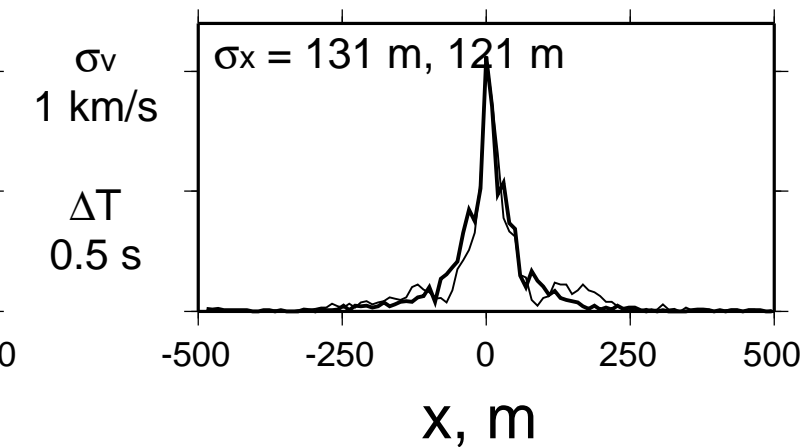
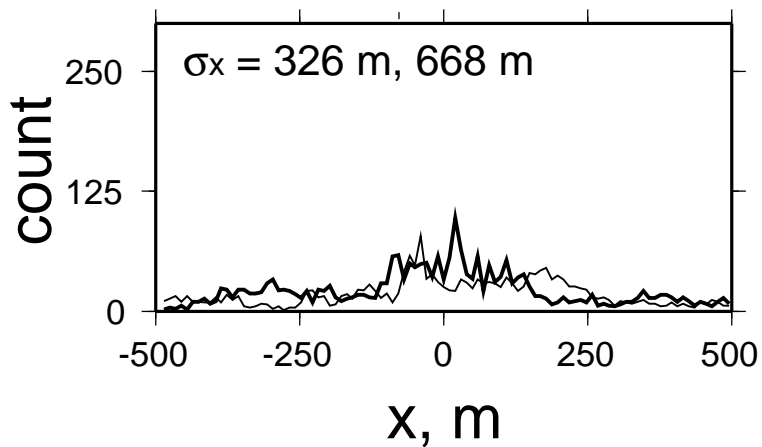
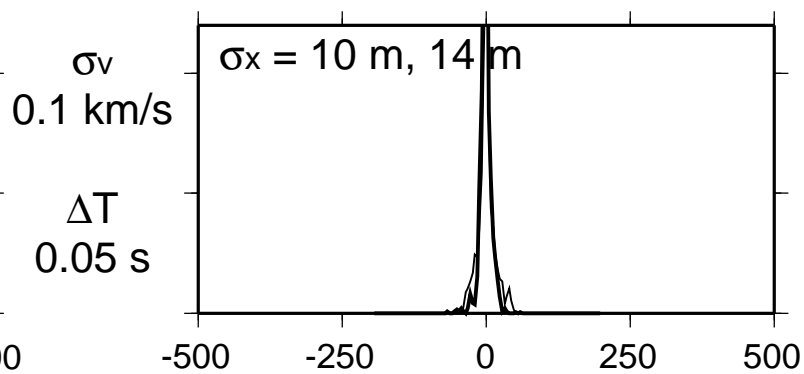
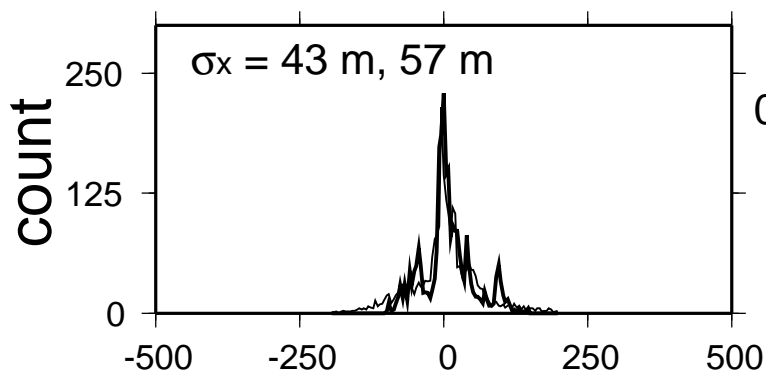
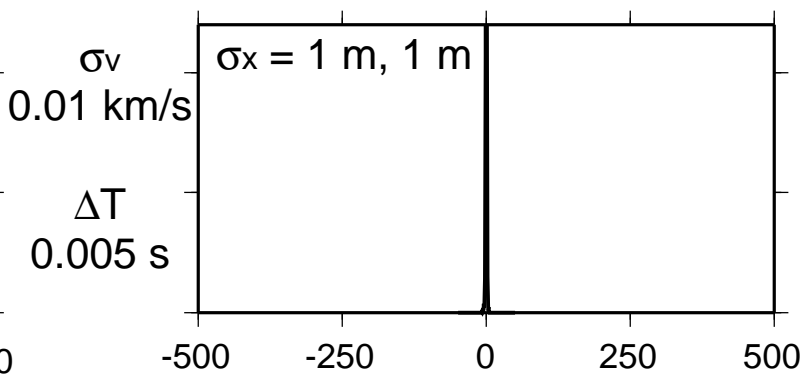
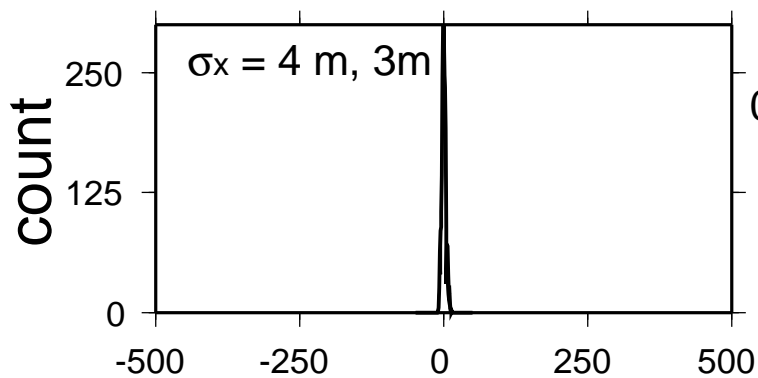

Near-Source Heterogeneities

A) Absolute Locations

B) Nearest Neighbor Distances

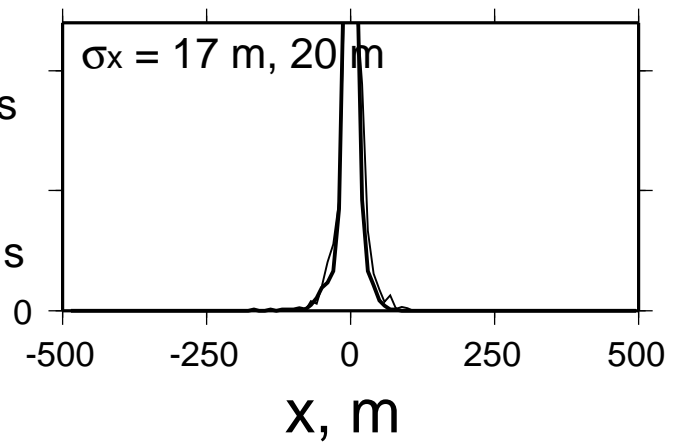
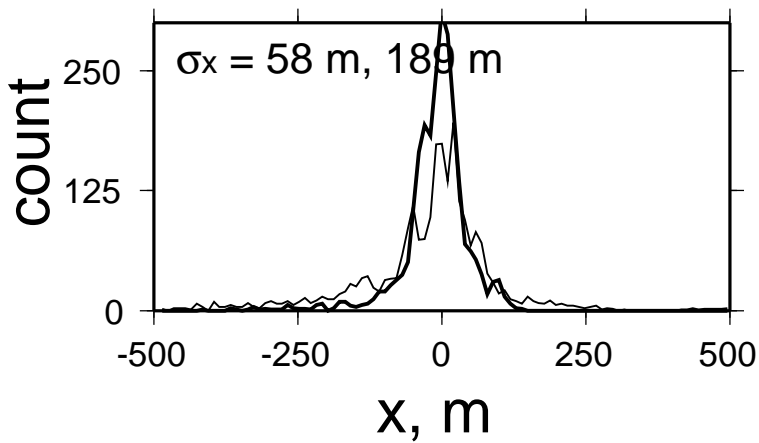
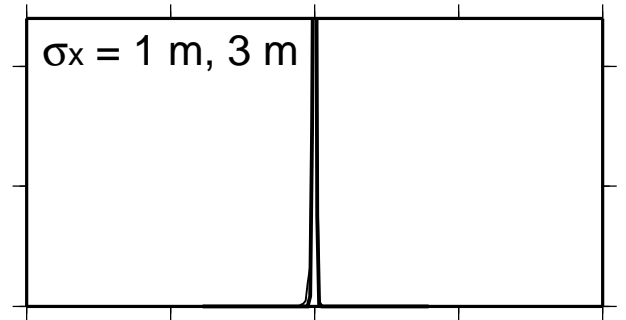
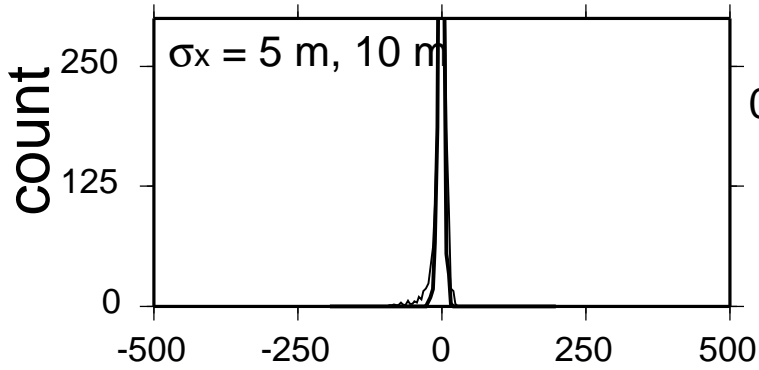
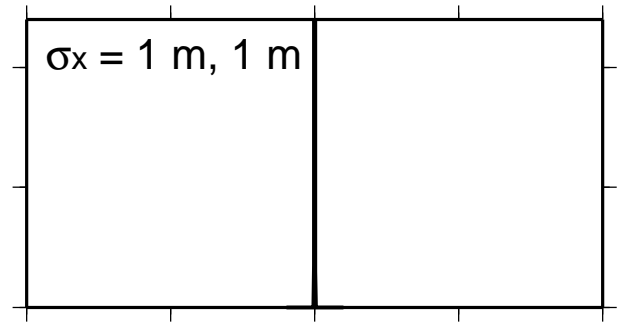
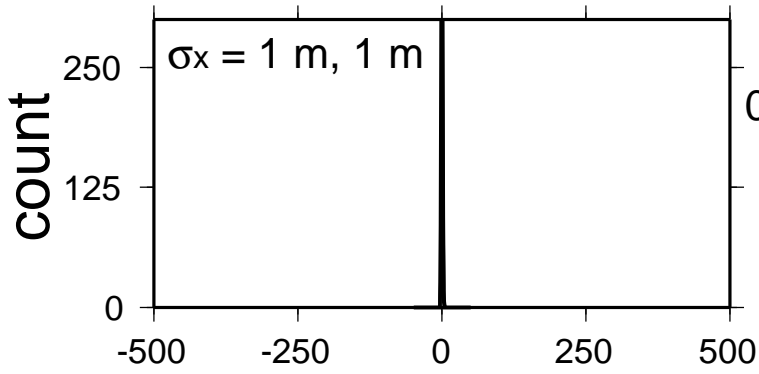

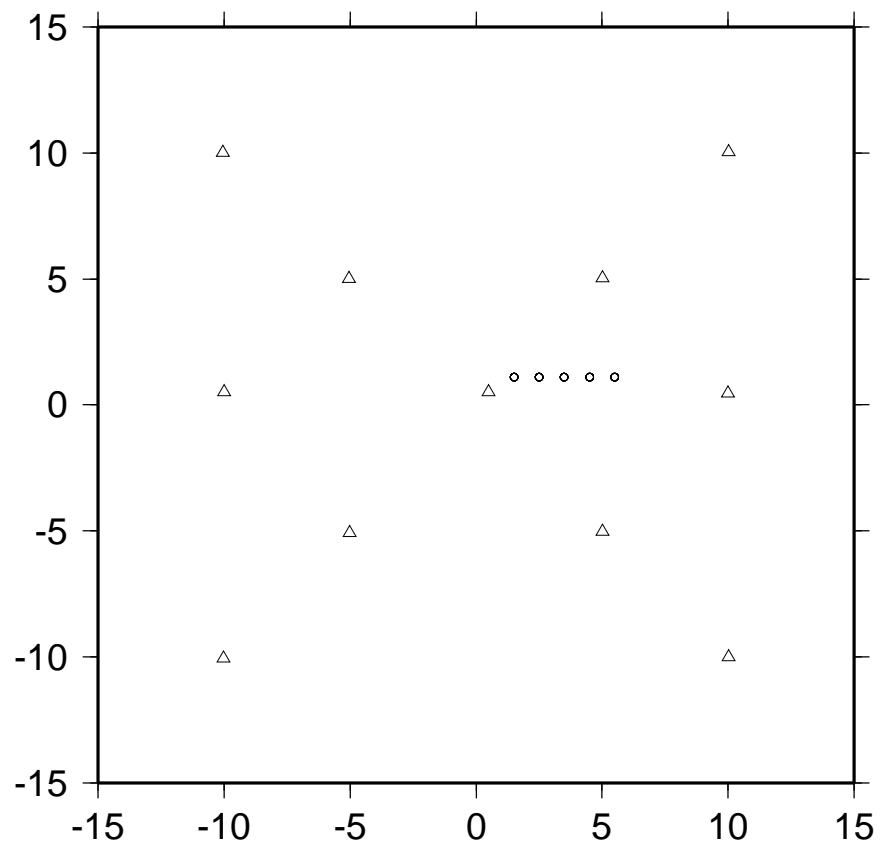

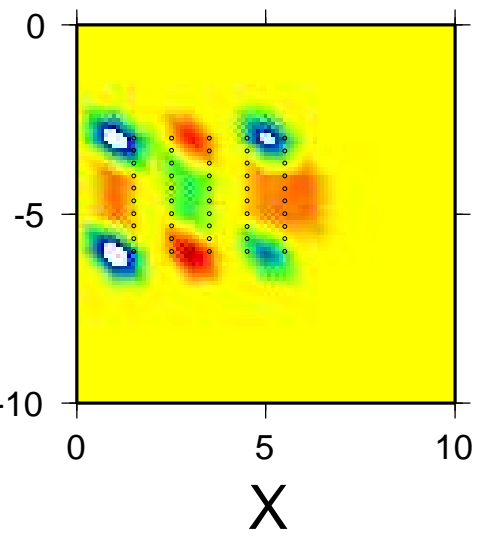
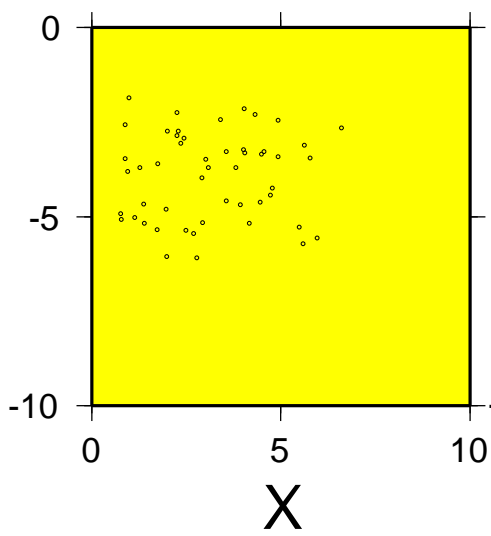
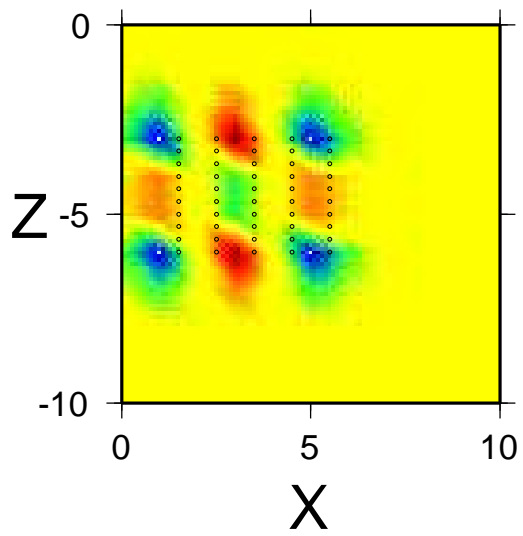

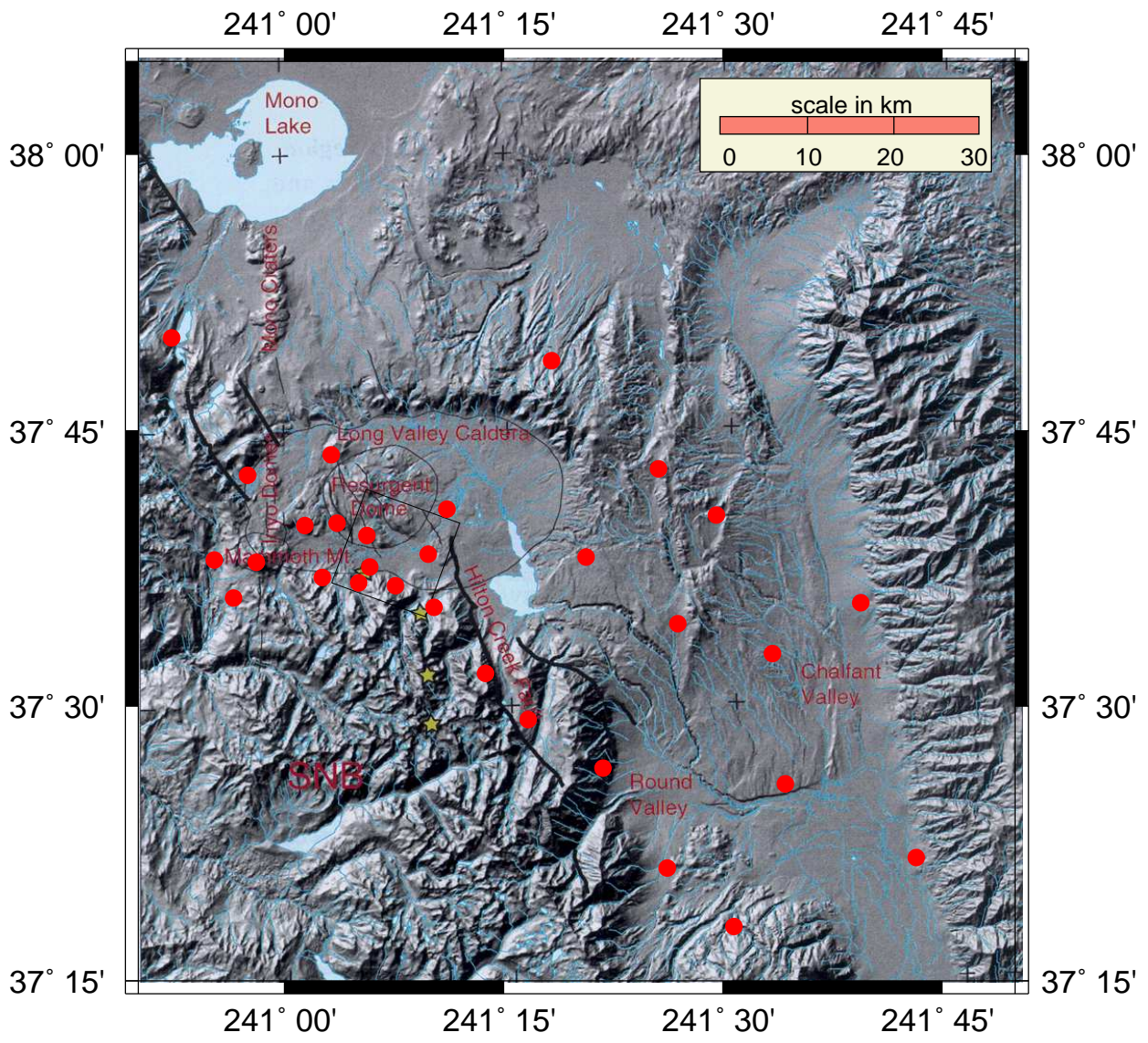

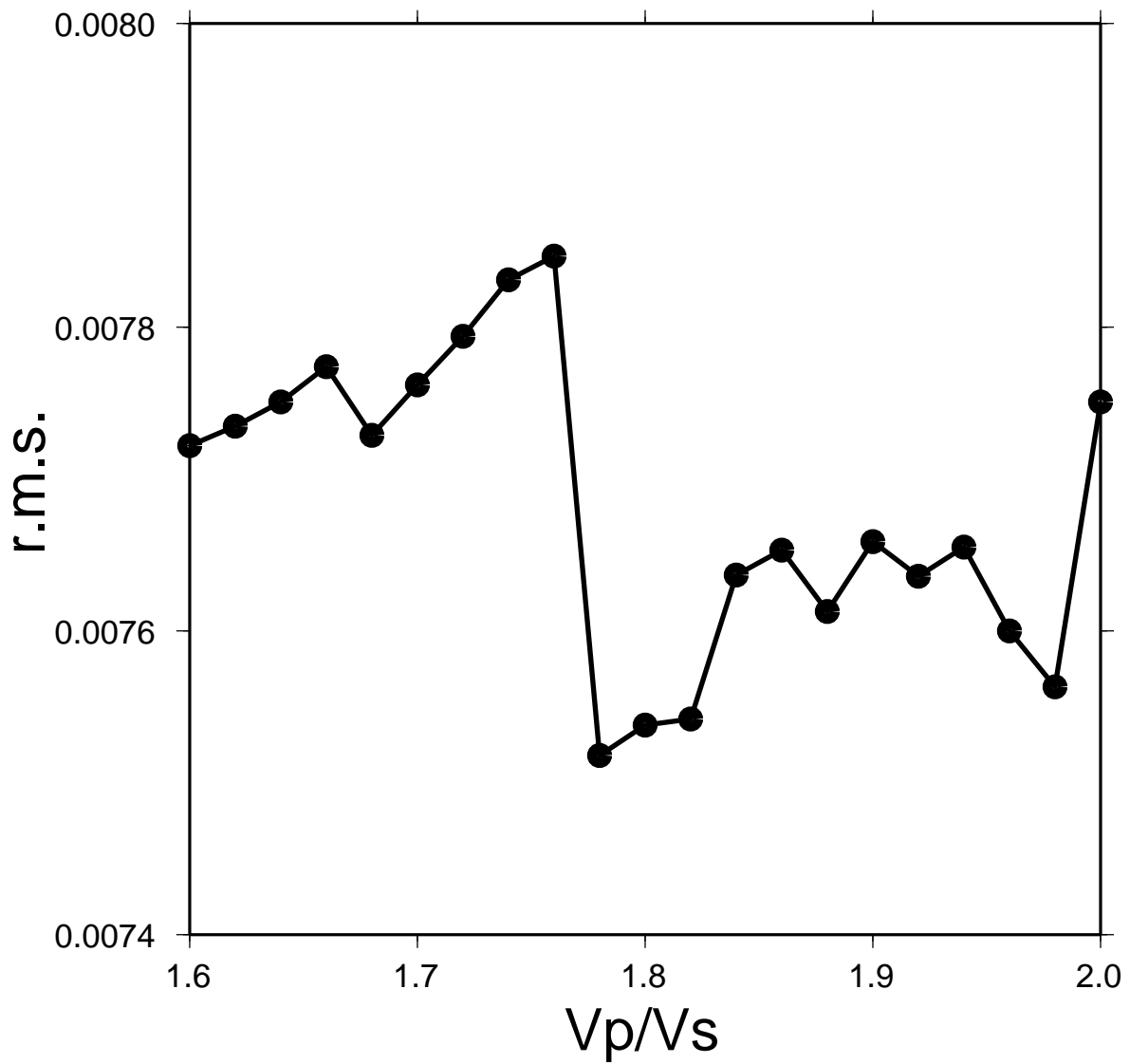

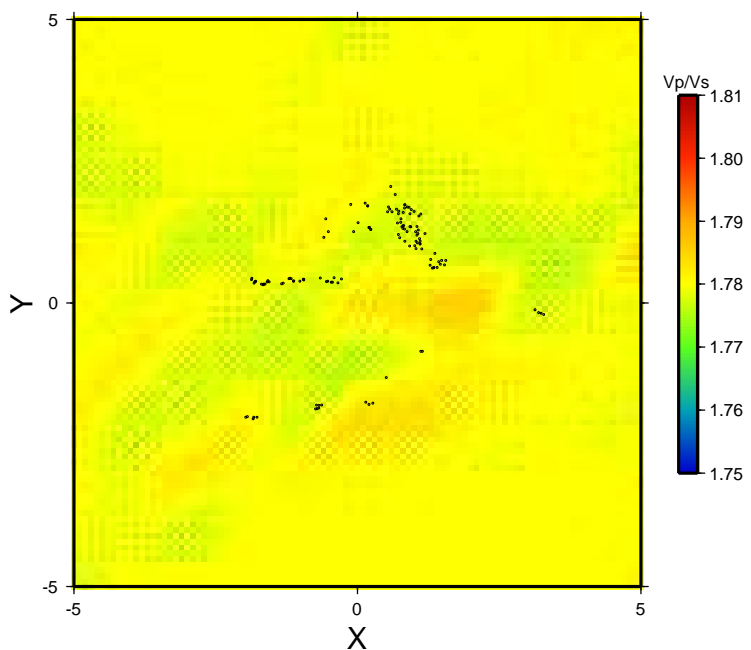
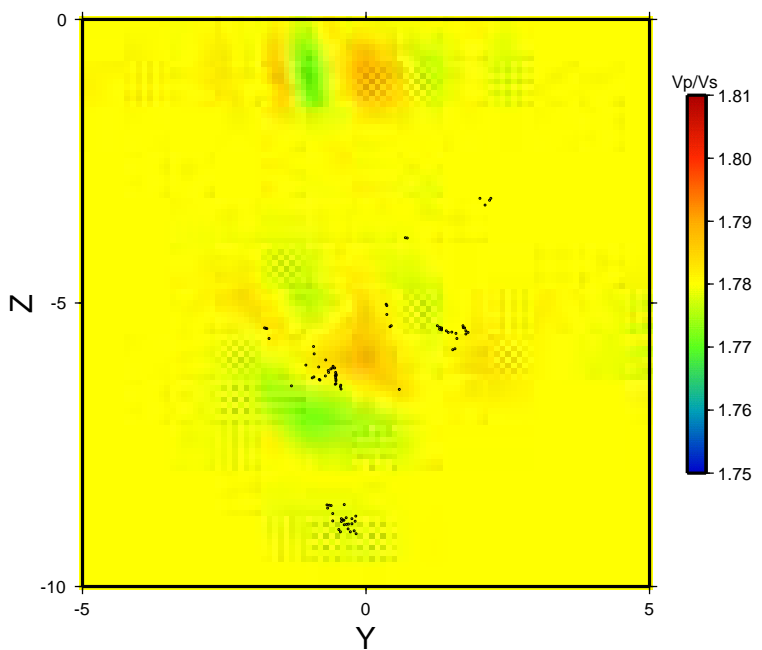
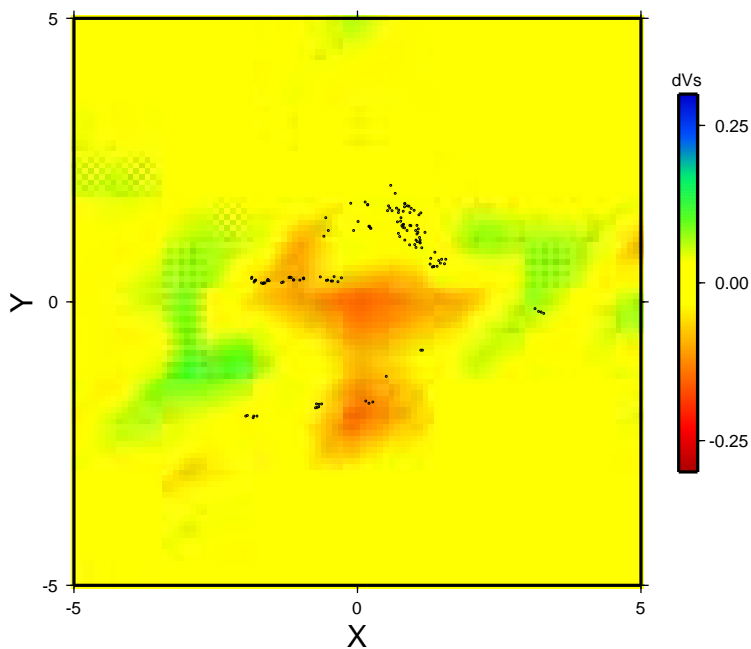
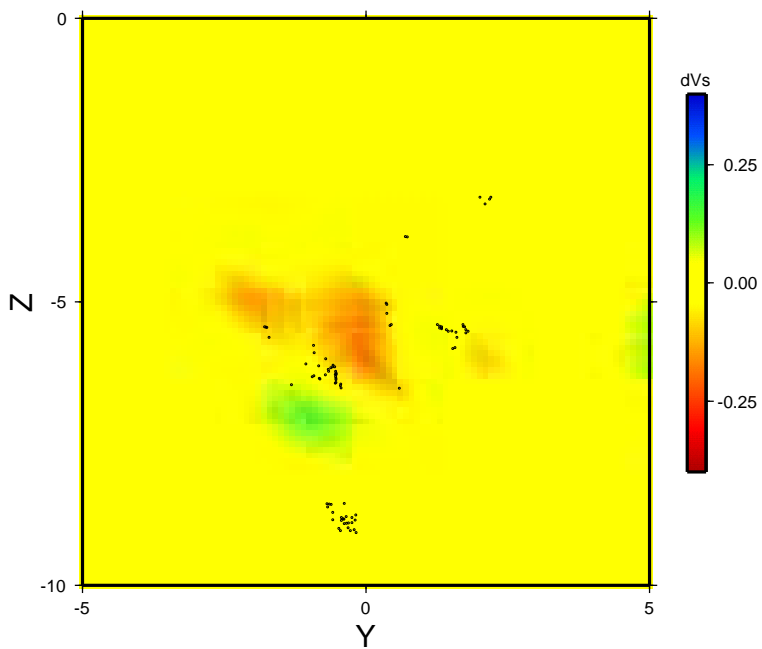
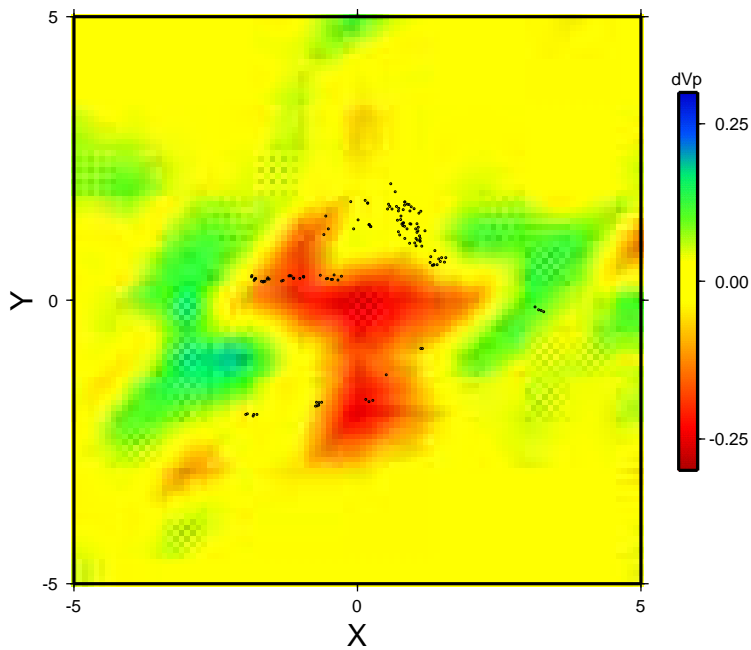
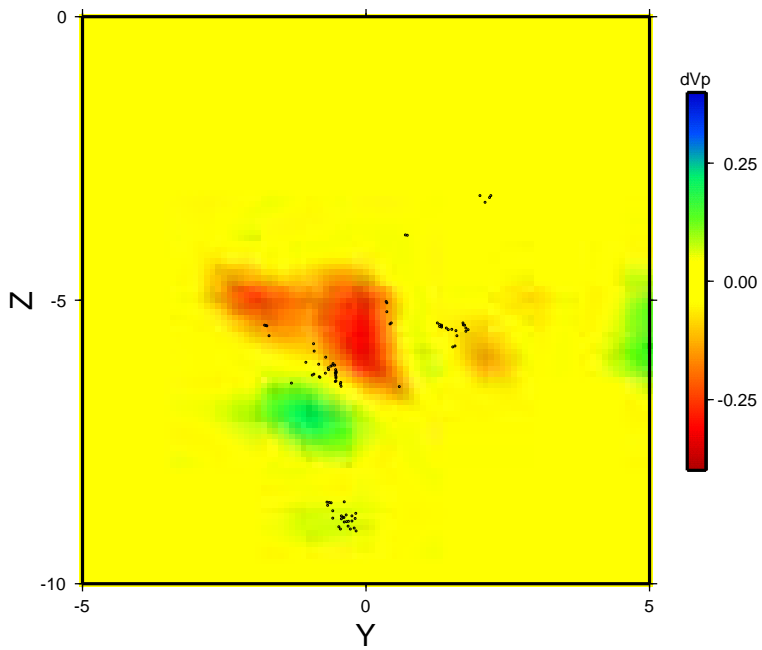

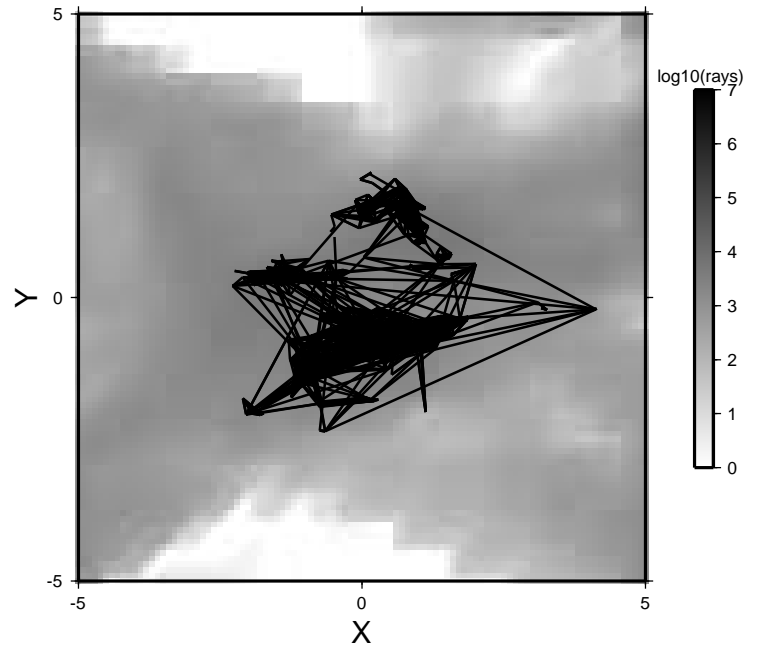
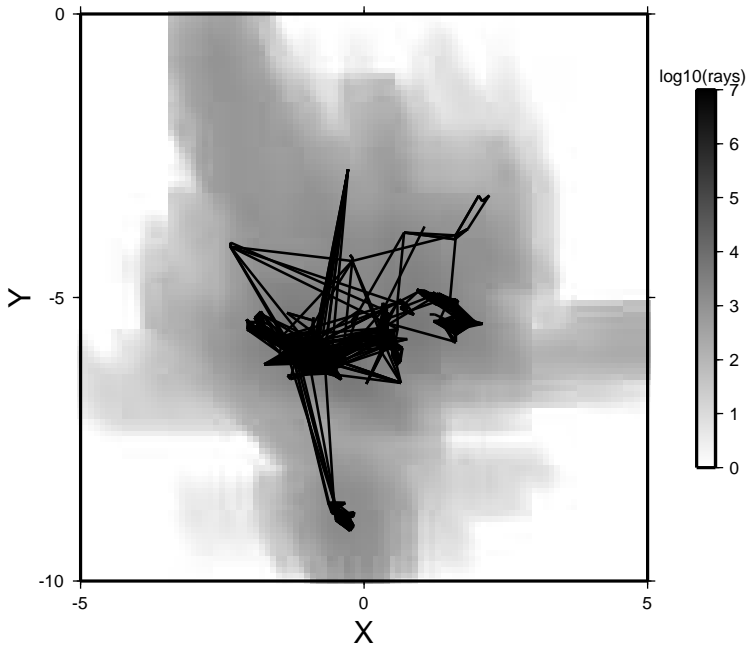

Conclusions

1. Earthquakes locations obtained using differential data are as good or better than locations obtained using traditional arrival time data and should be used in preference to the traditional methodology.
2. Noise characteristics of differential data, and especially degree of correlation of overlapping pairs is still very murky. More research on this topic is needed.
3. Simultaneous earthquake location and tomography using differential data works, for example, when applied to Long Valley, CA dataset. However the 10% improvement traveltime residuals, from 7.5 to 6.9 ms is modest at best. More experience is needed to build confidence in the tomographic images.